

WPR-48

Waterproof Handheld Remote

The WPR-48 is the industry's first waterproof RF wireless remote. Perfect for controlling music, television, lighting and more, the Crestron® "remote on a rope" is safe to use in the shower or hot tub. The ruggedized, immersible case is easy to grip and won't slip from moist hands.

Configurable for 9, 18, 27, or 48 functions, the WPR-48 features a total of nine multi-function pushbuttons that can be toggled left or right, or pressed in the center for up to 3 functions per button. Large customizable labels with electroluminescent backlighting facilitate use under any lighting condition.

The WPR-48 can communicate via RF or IR^[1] with any Crestron control system! Compatible with **CNRFGWA**, **CNRFGWA-418**, and **MC2W** 1-way RF gateways; the **CNXRMIRD** IR receiver; the **C2N-IRGW-1G** and **C2N-IRGW-F** IR gateways; and the **CN-TVAV** control module, the WPR-48 fits easily into any control system design. Long-life lithium ion rechargeable batteries afford several weeks of wireless use on a single charge, and are easily recharged when the remote is placed in the docking station (included).

- > *Waterproof handheld remote*
- > *Configurable for 9, 18, 27, or 48 function*
- > *Multi-function buttons allow single-press, 2-position or -position rocker action*

- > *Customizable labeling*
- > *Electroluminescent backlighting*
- > *1-way RF or IR wireless communication^[1]*
- > *Long-life lithium rechargeable batteries*
- > *Includes docking station/charger and lanyard*

SPECIFICATIONS

Function: Shift: The bottom function button may be used as a left/right shift button, selecting between 2 "pages" of commands

RF Wireless

RF Transmitter: 433.92 (433) or 418 MHz 1-way RF
Bandwidth: ±100KHz
Range: Up to 300 feet typical, subject to site-specific conditions
Gateway: Requires a **CNRFGWA**, **CNRFGWA-418**, or **MC2W** RF Gateway (each sold separately)

IR Wireless

IR Transmitter: 38 or 455 kHz IR^[1]
Formats: RC5 (38 kHz), Crestron (455 kHz)
Range: Up to 15 feet (typical)
Gateway: Requires a **C2N-IRGW-1G** or **C2N-IRGW-F** IR Gateway, **CNXRMIRD** IR Receiver, or **CN-TVAV** Control Module (each sold separately)

Indicators

T: (1) red LED, indicates WPR-48 is transmitting
B: (1) red LED, indicates battery is charging



?, ? : (2) red LEDs, indicate "page" selection in 48-function mode

Battery

Type: Li-Ion, 3.6 Volts DC, 750mah
Usage per Charge: Up to 5 hours (backlight on continuous), up to 4 weeks (typical home use)
Charging Time: 1.5 hours (maximum)

Power Requirements

Power Pack: 0.5 Amp @ 12 Volts DC;
120 Volts AC, 60 Hz power pack, model **PW-1205**, included;
Power connection made via the **WPR-DS** docking station/charger (included)

Enclosure

High impact rubberized blue plastic, watertight (at a depth of 10 feet for 10 minutes), includes optional lanyard and "foot" for angled tabletop operation

Environmental

Temperature: 32° to 140° F (0° to 60° C)
Humidity: 0% to 100% RH (non condensing)

Dimensions

Height: 5.26 in (134 mm)
Width: 2.79 in (71 mm)
Depth: 1.16 in (30 mm) with lanyard foot installed;
0.82 in (21 mm) with blank foot

Weight

4.8 oz (140 g)

WPR-48 Waterproof Handheld Remote

INTERNATIONAL VERSION (230 VAC)

WPRI-48

All the features and specifications of the WPR-48 except:

Power Requirements

Power Pack: 0.5 Amp @ 12 Volts DC;
230 Volts AC, 50 Hz power pack, model **PWI-1215**, included;
Power connection made via the **WPRI-DS** docking station/charger (included)

Available Models

WPR-48 [6500898]: Water-resistant 1-Way RF/IR Handheld Remote with (9) multi-function hard buttons configurable for up to 48 functions. Includes WPR-DS. Requires CNRFGWA, CNRFGWA-418, MC2W, C2N-IRGW, CN-TVAV, or CNXRMIRD.

WPRI-48 [6500917]: Water-resistant 1-Way RF/IR Handheld Remote with (9) multi-function hard buttons configurable for up to 48 functions - International Version, 230VAC. Includes WPRI-DS. Requires CNRFGWA, CNRFGWA-418, MC2W, C2N-IRGW, CN-TVAV, or CNXRMIRD.

Included Accessories

WPR-DS [6500899]: Docking Station/Charger [Included Quantity for WPR-48]
PW-1205 [6500823]: Wall Mount Power Pack, 12VDC, 0.5A, 2.5mm, US/NA [Included Quantity for WPR-48]

WPRI-DS [6500918]: Docking Station/Charger - International Version, 230V [Included Quantity for WPRI-48]

PWI-1215 [6500888]: Desktop Power Pack, 12VDC, 1.5A, 2.5mm, Universal [Included Quantity for WPRI-48]

Available Accessories

CNRFGWA [6500277]: 433MHz 1-Way RF Gateway [Discontinued]

CNRFGWA-418 [6500278]: 418MHz 1-Way RF Gateway

MC2W: Compact Control System with Built-in 1-Way RF Receiver/Gateway, 418/434 MHz Selectable. Includes PW-2420RU. [Discontinued]

C2N-IRGW-1G [6500390]: Wall Mount IR Gateway

C2N-IRGW-F [6500389]: Flush Mount IR Gateway

CNXRMIRD [6500430]: Plasma-proof IR Receiver for control systems and room solution boxes that have a compatible IR Input port

CN-TVAV [6500763]: TV/AV Controller Module, Cresnet. Includes one (1) STIRP.

ST-PK: Programming Cable Kit [Discontinued]

Notes:

1.
When IR wireless is enabled, the RF transmitter is disabled.
This product may be purchased from an authorized Crestron dealer. To find a dealer, please contact the Crestron sales representative for your area. A list of sales representatives is available online at www.crestron.com/salesreps or by calling 800-237-2041.

Crestron and the Crestron logo are trademarks or registered trademarks of Crestron Electronics, Inc. in the United States and other countries. Other trademarks and trade names may be used in this document to refer to either the entities claiming the marks and names or their products. Crestron disclaims proprietary interest in the marks and names of others. ©2011 Crestron Electronics, Inc.

WPR-48 Waterproof Handheld Remote

Front

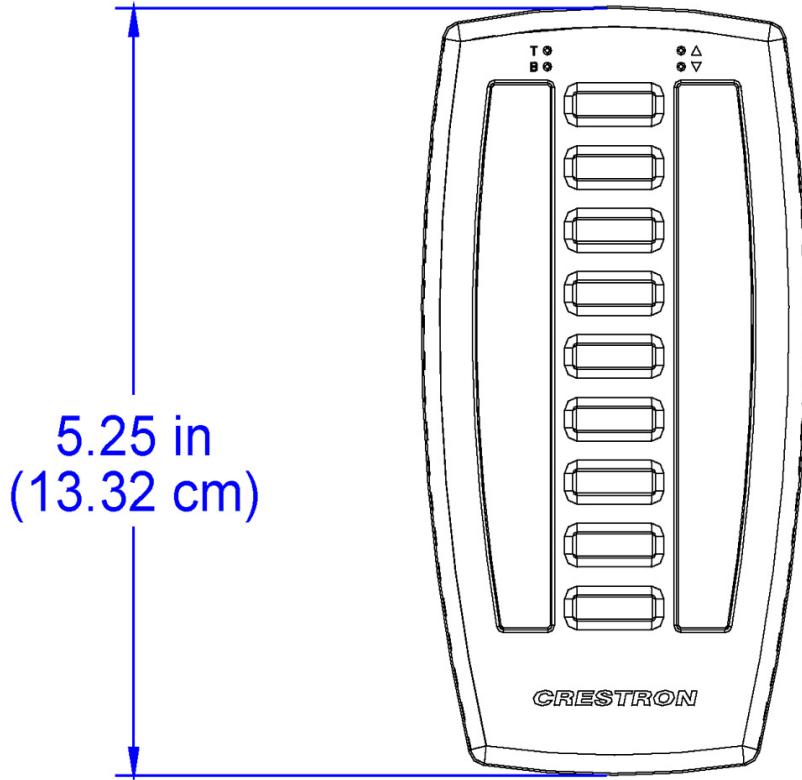

Back

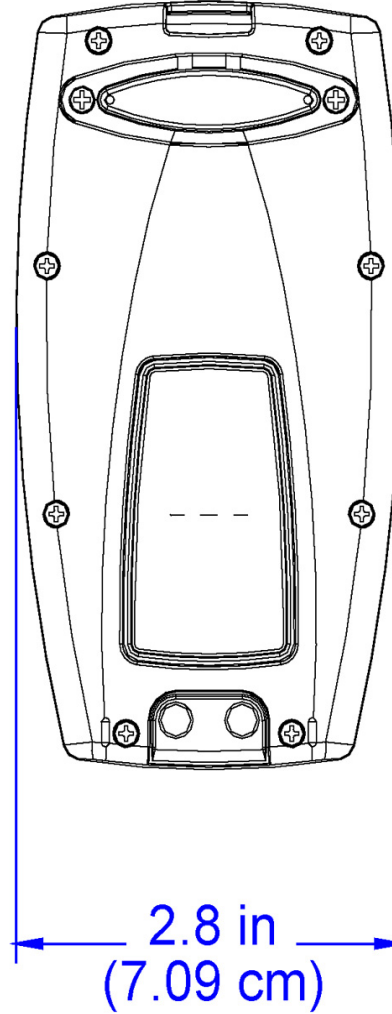

Side

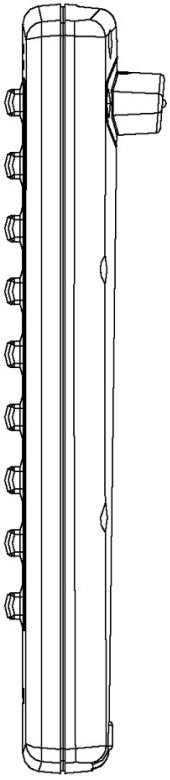

End

