

zalety

- 1 **REGULACJA POŁOŻENIA**
3 osie obrotu
- 2 **MAKSYMALNE OBCIĄŻENIE**
do 60 Kg
- 3 **SZYBKI MONTAŻ**
łatwa instalacja produktu

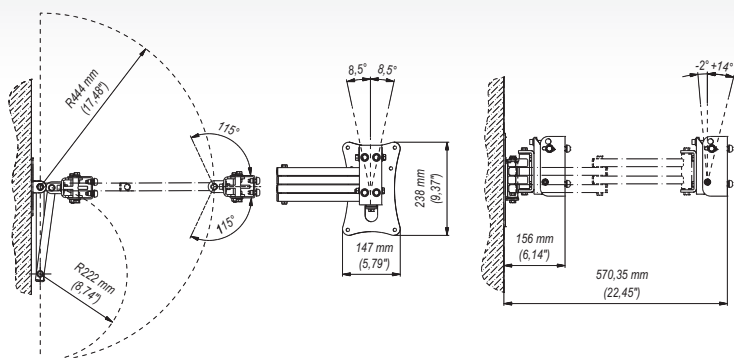

dane techniczne



100x100 mm 200x100 mm 200x200 mm 300x300 mm 400x200 mm 400x400 mm 600x400 mm 800x200 mm 800x400 mm	115°/115°	26"-40"	min. 156 mm max. 570,35 mm
-2°/+14°	60 Kg	-8,5°/+8,5°	
			min. 50x75 mm max. 850x460 mm

dane handlowe

index	kolor	opakowanie	EAN
SAL1c-R	■		5908252961290
SAL1c-B	■		5908252960231
SAL1s-R	■		5908252961306
SAL1s-B	■		5908252960248

wymiary opakowania [mm] (dl. x szer. x wys.)	670x270x95
Waga Brutto [Kg]	4.7

akcesoria

LWB1/PWB1/TWB1

