



## VS-801xlm

Vertical Interval Video Audio Switcher



The VS-401xlm, VS-601xlm, **VS-801xlm**, VS-1001xlm, and VS-1201xl are high performance switchers for composite video and unbalanced audio signals. Switching during the vertical interval ensures glitch-free switching with genlocked sources.

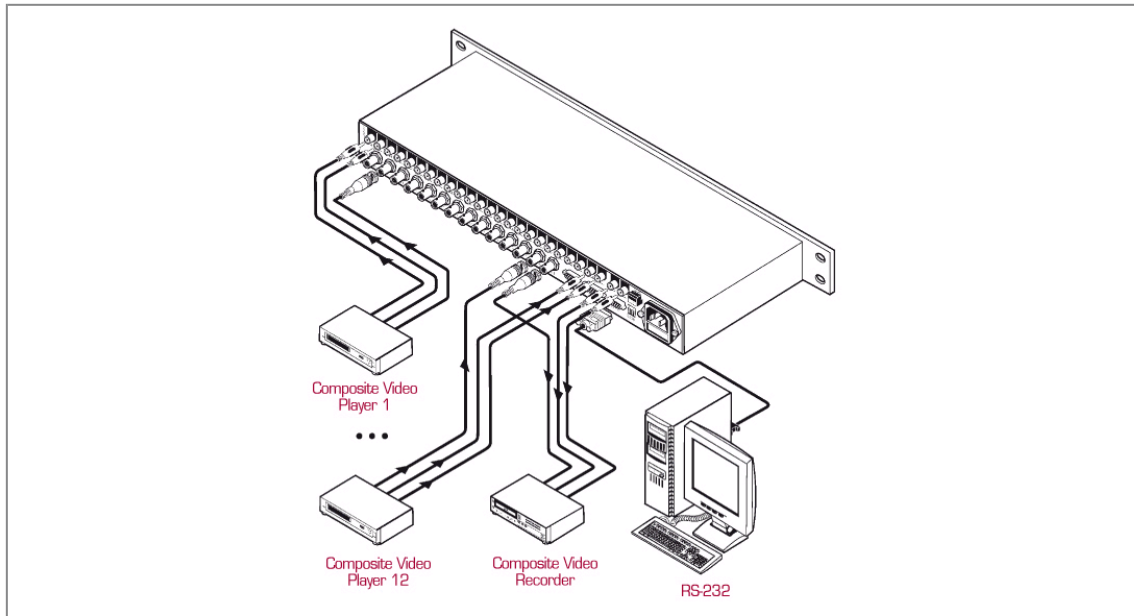



## VS-801xlm

### FEATURES

- High Bandwidth - 400MHz (- 3dB) for XLM & 250MHz for VS-1201xl.
- Vertical Interval Switching.
- Switching Synchronization - Synchronize either to external reference or the incoming video.
- Control - Front panel RS-232 K-Router™ Window® - based software is included), RS-485, & contact closure.
- Outputs - 3 audio & video (xlm models).
- Standard 19" Rack Mount Size - 1U.

### TECHNICAL SPECIFICATIONS

INPUTS:	10, 8, 6, 4 composite / single component Video, 1Vpp/75 Ω , on BNCs. 10, 8, 6, 4 audio stereo, +4dBm, 10kΩ, on RCA connectors. 1 external sync input (or composite video) 1Vpp/75 Ω on a BNC connector, RS-232 on 9pin D-sub, RS-485 on te
OUTPUTS:	1 : 3 composite / single component video, 1Vpp/75Ω on a BNC. 1 x 3 audio stereo up to +28Vpp /50Ω, (24dBm) on RCAs.
BANDWIDTH (VIDEO):	400 MHz -3dB (typical).
BANDWIDTH (AUDIO):	55 kHz, -0.1dB.
NON LINEARITY:	< 0.1%
AUDIO THD+NOISE:	0.02%.
DIFF. PHASE:	0.03 Deg.
DIFF. GAIN:	0.04%.
2nd HARMONIC:	<0.003% (1kHz).
AUDIO CROSSTALK:	-79 dB.
VIDEO S/N:	>77 dB.
AUDIO S/N RATIO:	> 90 dB, Unweighted.
K-FACTOR:	<0.05%.
CONTROL:	4-10 illuminated front-panel touch switches, RS-232, RS-422, contact closure.
DIMENSIONS:	19 inch (W), 7 inch (D) 1U (H) rack mountable.
POWER SOURCE:	230 VAC, 50/60 Hz, (115VAC U.S.A.) 16 VA (VS-1211).
WEIGHT:	3.1 kg (6.88 lbs.) Approx.
ACCESSORIES:	Power cord, Windows 95/98 control software, Null modem adapter.