

C2N-SSC-2

Somfy® Shade Controller

The C2N-SSC-2 Somfy Shade Controller is a compact Cresnet device designed to provide a bidirectional serial interface for up to two Somfy ILT Intelligent Shade Motors. Window treatments equipped with the Somfy ILT motor offer enhanced capability compared to typical three-wire models.

In addition to basic open/close commands, the C2N-SSC-2 allows for setting each shade to a specific position and polling for its current position with 16-bit precision. Feedback signals provide confirmation of each motor's activity to enable precise, predictable control, even from a remote location. Limit adjustments are set electronically using buttons provided on the face of the unit, and up to 20 presets for each output can be saved onboard the C2N-SSC-2 for easy recall through the control system. The C2N-SSC-2 mounts discreetly to any flat surface and requires a simple Cresnet connection to the control system.

SPECIFICATIONS

Connectors

1 - 2: (2) 4-position, 4-conductor RJ11 female; Intelligent Shade Motor control ports; Each port provides proprietary serial control of (1) Somfy ILT shade motor; Maximum Cable Length: 50 ft (15 m)
NET: (1) 4-pin 5mm detachable terminal block; Cresnet slave port, connects to Cresnet control network

Buttons

UP LIMIT (1 - 2): (2) buttons select up limit adjust mode for either motor
DWN LIMIT (1 - 2): (2) buttons select down limit adjust mode for either motor
UP: (1) button moves selected shade up while in limit adjust mode
DOWN: (1) button moves selected shade down while in limit adjust mode
SETUP: (1) button used for touch-settable ID (TSID)

LED Indicators

PWR: (green) Indicates DC power supplied from Cresnet network
NET: (yellow) Indicates communication with the Cresnet system
SETUP: (red) For touch-settable ID (TSID), updating firmware, and setting limits

Power Requirements

Cresnet Power Usage: 1.0 Watt (0.04 Amps @ 24 Volts DC)

Environmental

Temperature: 41° to 122°F (5° to 50°C)
Humidity: 10% to 90% RH (non-condensing)

Enclosure

Black metal, surface mount box with (2) integral mounting flanges

Dimensions

Height: 0.94 in (2.39 cm)
Width: 2.14 in (5.44 cm)
Depth: 3.83 in (9.73 cm)

Weight

0.25 lb (0.11 kg)



C2N-SSC-2 Somfy® Shade Controller

Top

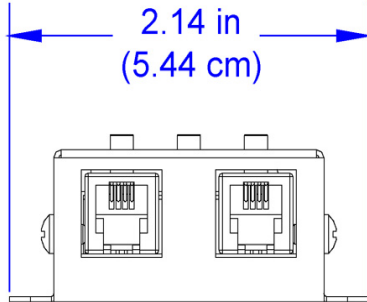

Front

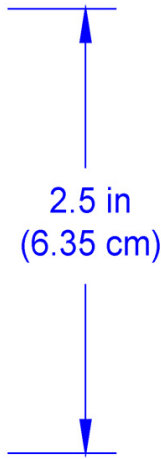
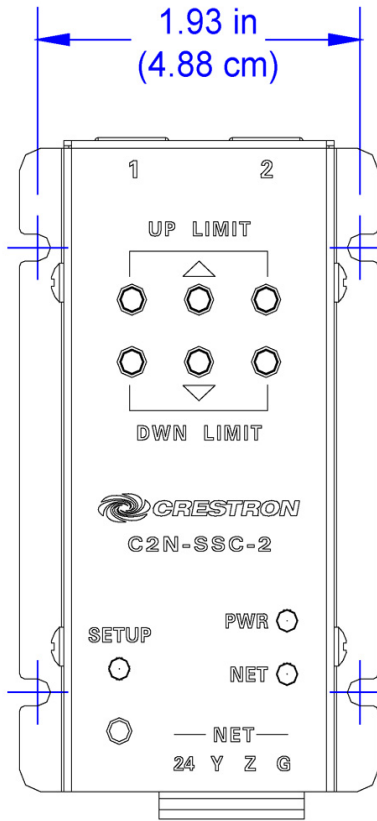

Side

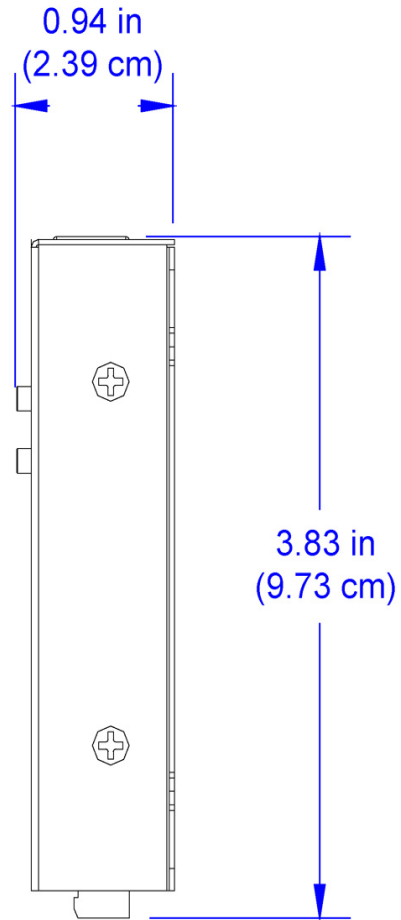

Bottom

