



KRAMER ELECTRONICS LTD.

USER MANUAL

MODEL:

SID-X1N
Step-in Commander

P/N: 2900-300302 Rev 4



SID-X1N Step-in Commander Quick Start Guide

This guide helps you install and use your product for the first time. For more detailed information, go to <http://bit.ly/k-prod-downloads> to download the latest manual or scan the QR code on the left.

Step 1: Check what's in the box

- SID-X1N** Step-in Commander
- 1 Power adapter (12V DC output)

- 4 Rubber feet
- Quick Start Guide

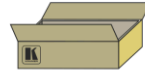

Step 2: Install the SID-X1N

Mount the device in a rack (using the optional **RK-T2B** rack adapter available for purchase) or attach the rubber feet and place it on a shelf.

Step 3: Connect the inputs and outputs

Always switch off the power to all devices before connecting them to your **SID-X1N**.

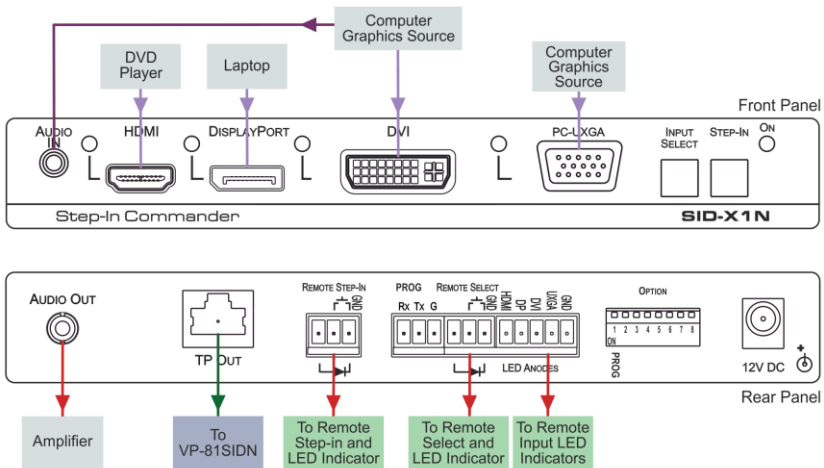

For best results, we recommend that you always use Kramer high-performance cables when connecting AV equipment to the **SID-X1N**. For optimum range and performance, use Shielded Twisted Pair (STP), non-skew free cable, such as the Kramer **BC-DGKat623** or **BC-DGKat7a23**.

Step 4: Set the DIP-switches

#	Feature	Function	Switch State
1	Program	Enables firmware updates	On—Enable updating Off—Disable updating
2	General Audio Control	Selects whether or not the analog audio is embedded in the output	On—Use embedded audio and DIP-switch 3 controls the DVI audio Off—Use analog audio
3	DVI Audio Control (active only when DIP-switch 2 is on)	Selects whether or not the analog audio is embedded in the DVI signal	On—Use analog audio in the DVI signal Off—Use the audio present on the DVI input
4	Video Mode Input Selection	Sets the video selection mode to either last connected or manual	On—Last connected Off—Manual
5	Lock EDID	Locks the current EDID	On—EDID locked Off—Automatic EDID selection
6	Switching Delay	Selects the time delay before switching occurs when an input cable is removed. Note: The delay is independent of the input switching mode	When the input signal is lost but the cable is not removed: On—0.5 seconds Off—10 seconds
			When the cable is removed: On—0.5 seconds Off—3 seconds
7	Output Disable Delay	Sets the time delay between loss of the input signal and out/PowerConnect shutdown	On—1 minute Off—15 minutes
8	Output Power Control	Enables/disables the output power in cases where the input signal is lost	On—Power is always on Off—Power is disabled when input signal is lost

Step 5: Connect the power



Connect the power adapter to the **SID-X1N** and plug the adapter into the mains electricity.

Note: Operation is fully automatic- no manual adjustment is needed.

Step 6: Operate the SID-X1N

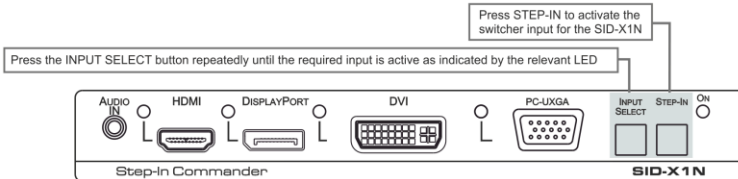

Optional: Lock the current EDID if required.

Contents

1	Introduction	1
2	Getting Started	2
2.1	Achieving the Best Performance	2
2.2	Safety Instructions	2
2.3	About the Power Connect Plus™ Feature	3
2.4	Shielded Twisted Pair/Unshielded Twisted Pair	3
2.5	Recycling Kramer Products	3
3	Overview	4
4	Defining the SID-X1N Step-in Commander	6
5	Connecting the SID-X1N	8
5.1	Connecting the Remote Step-In Switch and LED	9
5.2	Connecting the Remote Select Switch and LED	10
5.3	Connecting the Remote Input Selection LEDs	11
6	Principles of Operation	12
6.1	Video Input Selection	12
6.2	Audio Signal Control	13
6.3	Automatic Output Shutdown	13
7	Operating the SID-X1N	14
7.1	Manually Selecting an Input	14
7.2	Taking Control of the Switcher Input	15
7.3	Locking the EDID	15
7.4	Adjusting the UXGA Input Phase	15
8	Configuring and Maintaining the SID-X1N	16
8.1	Setting the Configuration DIP-switch	16
9	Wiring the Twisted Pair RJ-45 Connectors	18
10	Technical Specifications	19
10.1	Supported Resolutions	20
11	Default EDID	22
11.1	HDMI, DisplayPort and DVI	22
11.2	PC-UXGA	24
12	Remote Commands	26
12.1	Syntax	26
12.2	Instruction Codes	27

Figures

Figure 1:	SID-X1N Step-in Commander Front Panel	6
Figure 2:	SID-X1N Step-in Commander Rear Panel	7
Figure 3:	Connecting the SID-X1N Step-in Commander	8
Figure 4:	Remote Step-In Switch and LED Wiring	9
Figure 5:	Remote Select Switch and LED Wiring	10
Figure 6:	Remote Input Indicator LED Connections	11
Figure 7:	Remote Input Indicator LED Wiring	11
Figure 8:	The Configuration DIP-switch	16
Figure 9:	TP Pinout Wiring	18

1 Introduction

Welcome to Kramer Electronics! Since 1981, Kramer Electronics has been providing a world of unique, creative, and affordable solutions to the vast range of problems that confront video, audio, presentation, and broadcasting professionals on a daily basis. In recent years, we have redesigned and upgraded most of our line, making the best even better!

Our 1,000-plus different models now appear in 14 groups that are clearly defined by function: GROUP 1: Distribution Amplifiers; GROUP 2: Switchers and Routers; GROUP 3: Control Systems; GROUP 4: Format/Standards Converters; GROUP 5: Range Extenders and Repeaters; GROUP 6: Specialty AV Products; GROUP 7: Scan Converters and Scalers; GROUP 8: Cables and Connectors; GROUP 9: Room Connectivity; GROUP 10: Accessories and Rack Adapters and GROUP 11: Sierra Video Products; GROUP 12: Digital Signage; and GROUP 13: Audio, and GROUP 14: Collaboration.

Thank you for purchasing the Kramer MegaTOOLS® **SID-X1N** *Step-in Commander* which is ideal for:

- Display systems requiring simple input selection
- Remote monitoring of computer activity in schools and businesses
- Rental/staging applications
- Multimedia and presentation source selection

2 Getting Started

We recommend that you:

- Unpack the equipment carefully and save the original box and packaging materials for possible future shipment
- Review the contents of this user manual



Go to http://www.kramerelectronics.com/support/product_downloads.asp to check for up-to-date user manuals, application programs, and to check if firmware upgrades are available (where appropriate).

2.1 Achieving the Best Performance

To achieve the best performance:

- Use only good quality connection cables (we recommend Kramer high-resolution, high-quality cables) to avoid interference, deterioration in signal quality due to poor matching, and elevated noise levels (often associated with low quality cables)
- Do not secure the cables in tight bundles or roll the slack into tight coils
- Avoid interference from neighboring electrical appliances that may adversely influence signal quality
- Position your Kramer **SID-X1N** away from moisture, excessive sunlight and dust



This equipment is to be used only inside a building. It may only be connected to other equipment that is installed inside a building.

2.2 Safety Instructions



Caution: There are no operator serviceable parts inside the unit

Warning: Use only the Kramer Electronics input power wall adapter that is provided with the unit

Warning: Disconnect the power and unplug the unit from the wall before installing

2.3 About the Power Connect Plus™ Feature

The Power Connect Plus™ feature means that only the **SID-X1N** needs to be connected to a power source when the **SID-X1N** and receiver are within 60m (197ft) of each other. The Power Connect Plus™ feature applies as long as the cable can carry power and the distance does not exceed 60m on standard TP cable. (Heavier gauge cable may be used to extend the Power Connect Plus™ range).

2.4 Shielded Twisted Pair/Unshielded Twisted Pair

Kramer engineers have developed special twisted pair cables to best match our digital twisted pair products; the Kramer **BC-DGKat623** (CAT 6 23 AWG cable), and the Kramer **BC-DGKat7a23** (CAT 7a 23 AWG cable). These specially built cables significantly outperform regular CAT 6 and CAT 7a cables.

2.5 Recycling Kramer Products

The Waste Electrical and Electronic Equipment (WEEE) Directive 2002/96/EC aims to reduce the amount of WEEE sent for disposal to landfill or incineration by requiring it to be collected and recycled. To comply with the WEEE Directive, Kramer Electronics has made arrangements with the European Advanced Recycling Network (EARN) and will cover any costs of treatment, recycling and recovery of waste Kramer Electronics branded equipment on arrival at the EARN facility. For details of Kramer's recycling arrangements in your particular country go to our recycling pages at <http://www.kramerelectronics.com/support/recycling/>.

3 Overview

The **SID-X1N** accepts an HDMI, DisplayPort, DVI and PC graphics video input, as well as an unbalanced stereo audio input (which is embedded into the output signal), and transmits the signal via TP (Twisted Pair) cable to a compatible switcher or DGK at receiver, (for example, the **VP-81SIDN** or **PT-572+**).

The **SID-X1N** also provides an unbalanced, stereo audio output. When the **SID-X1N** is connected to a switcher, it also controls the input and output selection of the switcher.

In particular the **SID-X1N** features:

- HDTV support
- HDMI with x.v.Color™ and 3D
- HDCP compliancy—works with sources that support HDCP repeater mode

Note: When using a MacBook as a source and the content is protected using HDCP, if the display does not support HDCP, no video is transmitted

- Input signal detection based on video clock presence
- Automatic input selection based on manual selection or last connected input
- Automatic analog audio detection and embedding
- Automatic output shutdown when the input signal is lost (with a configurable delay)
- Installation up to 50m (164ft) from the switcher, (30m with the **TP-574**)
- I-EDIDPro™ Kramer Intelligent EDID Processing™ – Intelligent EDID handling & processing algorithm ensures Plug and Play operation for HDMI systems
- A lockable EDID
- VGA phase adjustment
- PowerConnectPlus – A single connection to the receiver powers both units. The higher voltage PowerConnectPlus also powers regular PowerConnect

devices via auto-negotiation

- Equalization and reclocking of the data
- A maximum data rate of 4.95Gbps (1.65Gb per graphics channel)
- Support for digital audio formats
- A MegaTOOLS® sized enclosure. Two devices can be mounted in a rack using the optional **RK-T2B** adapter

You can control the **SID-X1N** using the front panel buttons or remotely via contact closure switches.

4 Defining the SID-X1N Step-in Commander

Figure 1 defines the front panel of the **SID-X1N**.

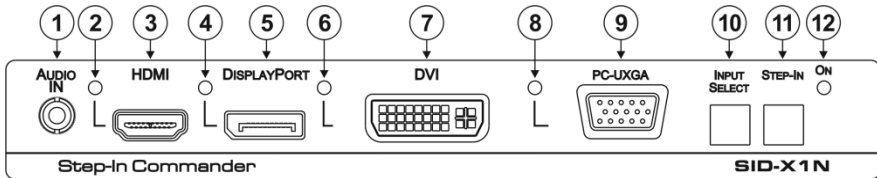

Figure 1: SID-X1N Step-in Commander Front Panel

#	Feature	Function
1	AUDIO IN 3.5mm Mini Jack	Connect to an unbalanced stereo audio source
2	HDMI	LED
3		HDMI Connector
4	DisplayPort	LED
5		DP Connector
6	DVI	LED
7		DVI Connector
8	PC-UXGA	LED
9		PC-UXGA 15-pin HD Connector (F)
10	INPUT SELECT Button	Press repeatedly to cycle through the inputs manually to select an input, (overrides automatic selection, see Section 7.1). Note: When the button is lit it is inactive and pressing the button will not activate the input
11	STEP-IN Button	Press to activate the input on the switcher that the SID-X1N is connected to, (see Section 7.2)
12	ON LED	Lights green when the device is powered on

Figure 2 defines the rear panel of the **SID-X1N**.

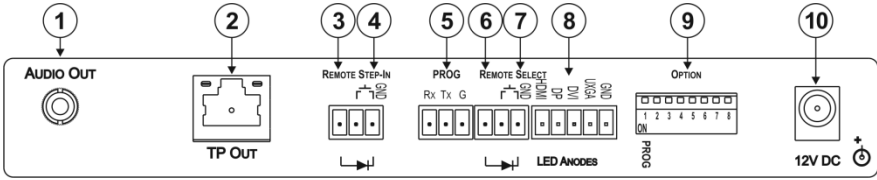

Figure 2: SID-X1N Step-in Commander Rear Panel

#	Feature	Function
1	AUDIO OUT 3.5mm Mini Jack	Connect to an unbalanced, stereo audio acceptor, (see Section 4)
2	TP OUT RJ-45 Connector	Connect to a compatible switcher or DGK at receiver, (for example, VP-81SIDN or PT-572+) using CAT 6 or higher specification cable
3	REMOTE STEP-IN	LED
4	3-pin Terminal Block	Switch
5	PROG RS-232 3-pin Terminal Block	Connect to the PC via RS-232 to perform a firmware upgrade
6	REMOTE SELECT	LED
7	8-pin Terminal Block	Switch
8	LED ANODES	LED HDMI, DP, DVI and UXGA
9	OPTION 8x DIP-switch	Sets the device behavior, (see Section 8.1)
10	12V DC Power Connector	Connect to the supplied power adapter, center pin positive

5 Connecting the SID-X1N



Switch off the power to all devices before connecting them to your **SID-X1N**. After connecting your **SID-X1N** connect the power to other devices.

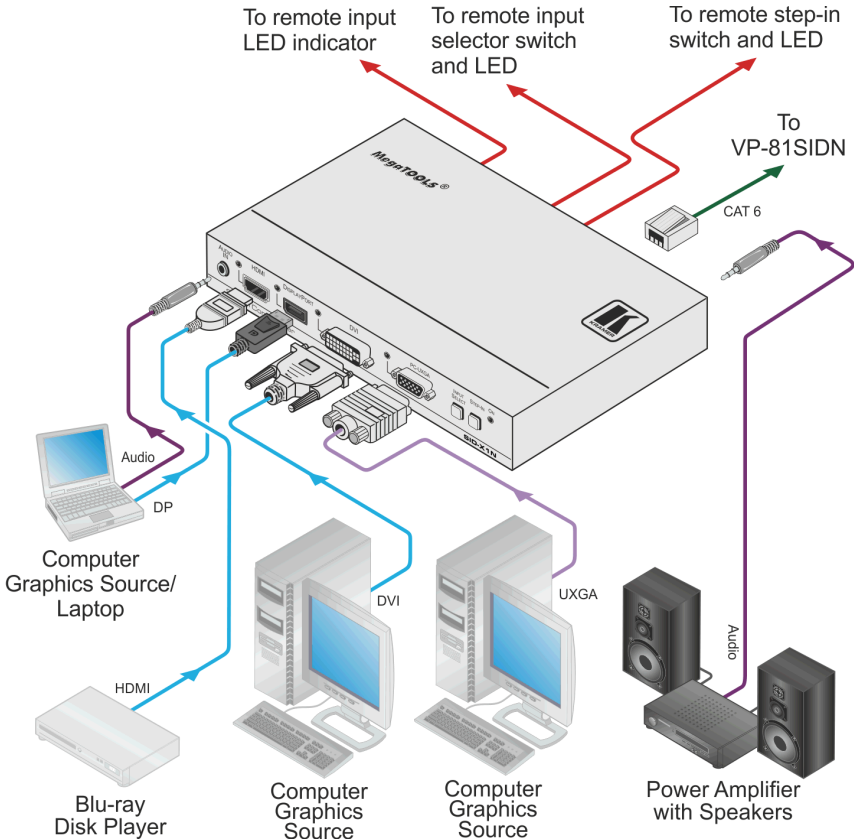

Figure 3: Connecting the SID-X1N Step-in Commander

To connect the SID-X1N as illustrated in [Figure 3](#):

1. Connect up to four video sources, (for example, a Blu-ray disc player, a laptop and two computer graphics sources) to the video input connectors.

2. Connect the unbalanced stereo audio source, (for example, the audio output from the laptop) to the AUDIO IN 3.5mm mini jack.
3. Connect the AUDIO OUT 3.5mm mini jack to the unbalanced, stereo audio acceptor, (for example, a power amplifier with speakers).
4. Connect the TP OUT RJ-45 connector to a compatible switcher, (for example, **VP-81SIDN**).
5. Connect the REMOTE STEP-IN 3-way terminal block to a contact-closure switch and LED (see [Section 5.1](#)).
6. Connect the REMOTE SELECT 3-way terminal block to a momentary contact-closure switch and LEDs (see [Section 5.2](#)).
7. Connect the LED ANODES 5-way terminal block to the remote input indicator LEDs (see [Section 5.3](#)).
8. Connect the power adapter to the **SID-X1N** and to the mains power.

Note: All LED supplies include a current limiting resistor and are designed to work with any standard LED.

5.1 Connecting the Remote Step-In Switch and LED

You can connect a remote, contact closure step-in switch to take control of the input of the attached switcher, as well as a remote step-in LED to the REMOTE STEP-IN terminal block on the rear panel of the **SID-X1N**.

[Figure 4](#) illustrates the connections from the terminal block to the switch and LED.

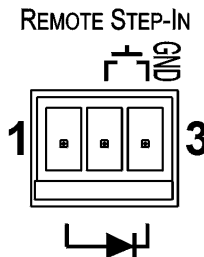

Figure 4: Remote Step-In Switch and LED Wiring

To connect a remote step-in switch and LED as illustrated in the example in [Figure 4](#):

1. Connect pins 2 and 3 from the terminal block to the remote step-in switch.
2. Connect pin 1 from the terminal block to the anode of the remote step-in LED.
3. Connect pin 3 from the terminal block to the cathode of the remote step-in LED.

5.2 Connecting the Remote Select Switch and LED

You can connect a remote, contact closure, input selection switch to activate an input (momentary contact is sufficient to switch inputs), as well as an indicator LED to the terminal block on the rear panel of the **SID-X1N**.

[Figure 5](#) illustrates the connections from the terminal block to the switch and LED.

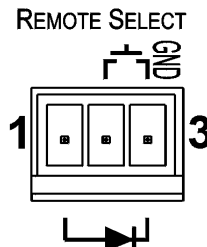

Figure 5: Remote Select Switch and LED Wiring

To connect a remote selection switch and LED as illustrated in the example in [Figure 5](#):

1. Connect pins 2 and 3 from the terminal block to the remote selection switch.
2. Connect pin 1 from the terminal block to the anode of the remote selection LED.
3. Connect pin 3 from the terminal block to the cathode of the remote selection LED.

5.3 Connecting the Remote Input Selection LEDs

You can connect remote, input selection LEDs to the LED terminal block on the rear panel of the **SID-X1N** to indicate which is the active input.

[Figure 6](#) illustrates the connections from the terminal block to the LEDs.

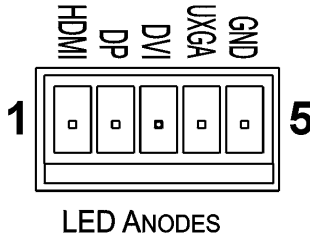

Figure 6: Remote Input Indicator LED Connections

To connect remote input indicator LEDs:

1. Connect pin 1 from the terminal block to the anode of the remote HDMI indicator LED.
2. Connect pin 2 from the terminal block to the anode of the remote DP indicator LED.
3. Connect pin 3 from the terminal block to the anode of the remote DVI indicator LED (see the example in [Figure 7](#)).
4. Connect pin 4 from the terminal block to the anode of the remote UXGA indicator LED.
5. Connect pin 5 from the terminal block to the cathode of each LED.

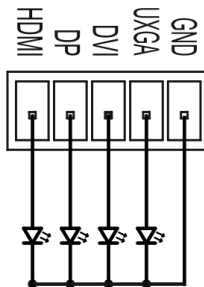

Figure 7: Remote Input Indicator LED Wiring

6 Principles of Operation

This chapter describes the principles of operation of the **SID-X1N** and comprises:

- Video input selection (see [Section 6.1](#))
- Audio signal control (see [Section 6.2](#))

The **SID-X1N** selects video and audio inputs based on the rules described below.

6.1 Video Input Selection

The video mode selection is set by the DIP-switches (see [Section 8.1](#)) to either of the following:

- Manual
- Last connected

In manual mode the input is selected using the front panel buttons. Only inputs with a live signal present can be selected.

In last connected mode the **SID-X1N** selects the input based on which input was connected last. If the signal on this input is subsequently lost for any reason, the input with a live signal with the highest priority is automatically selected. The priority from highest to lowest is:

- HDMI
- DisplayPort
- DVI
- PC

Note: In last connected mode, manually selecting an input using the front panel Input Select button overrides the last-connected automatic selection.

When an input cable is removed, there is a delay of either 0.5 or 3 seconds, (selectable, see [Section 8.1](#)) before automatic switching takes place. After that, another input can be automatically selected according to the signal priority shown above.

6.2 Audio Signal Control

The Option DIP-switches 2 and 3 (see [Section 8.1](#)) control the manner in which audio is handled.

The following table describes which audio signal is embedded in the output.

DIP-switch 2	DIP-switch 3	3.5mm Mini Jack	Input	Audio on Output
On/Off	On/Off	On/Off	VGA	3.5mm mini jack
Off	On/Off	Inserted	HDMI/DP/DVI	3.5mm mini jack
		Not inserted		Embedded HDMI/DP/DVI
On	On/Off	Inserted/Not inserted	HDMI/DP	Embedded HDMI/DP
On	Off	Inserted/Not inserted	DVI	Embedded DVI
On	On	Inserted/Not inserted		3.5mm mini jack

6.3 Automatic Output Shutdown

The **SID-X1N** can disable the output (signal and 5V) when there is no signal for a specified period in:

- Manual mode—when the signal on the currently selected input is lost
- Automatic mode—when there is no signal on any of the inputs

The delay period is set by the DIP-switch, (see [Section 8.1](#)). At the end of this period, both the output signal and the power supply to other devices (via PowerConnect) are disabled.

The return of an input signal on either the currently selected input (in manual mode), or on any input (in automatic mode), immediately re-activates the output and turns on PowerConnect.

7 Operating the SID-X1N

This chapter describes the operating procedures of the **SID-X1N** and comprises:

- Manually selecting an input (see [Section 7.1](#))
- Taking control of the switcher input (see [Section 7.2](#))
- Locking the EDID (see [Section 7.3](#))

Powering up the **SID-X1N** recalls from the non-volatile memory the last settings that were in force when the device was powered down.

The **SID-X1N** inputs can be selected remotely via the **VP-81SIDN**. For details on how to do so, see the **VP-81SIDN User Manual**.

7.1 Manually Selecting an Input

Note: When the button is lit it is inactive and pressing the button will not activate the input.

To manually select an input:

- Press the INPUT SELECT button repeatedly until the required input is active as indicated by the associated LED.

Note: Only inputs that have an active signal can be selected.

Note: The manual selection overrides any input selection when in last connected mode and remains in effect until the device is power cycled.

7.2 Taking Control of the Switcher Input

To activate the input of the switcher to which the **SID-X1N** is connected, press the STEP-IN button. If the switcher grants the **SID-X1N** access to the input, the STEP-IN button lights. If the switcher does not grant access for some reason, the button flashes for a few seconds and then does not light. One reason for this may be that the switcher input connected to the **SID-X1N** has been set to have a lower priority than the currently active input.

Note: Input priority on the switcher is set using the Kramer Control Software.

7.3 Locking the EDID

The currently stored EDID can be locked to prevent it from being overwritten. To lock the current EDID, set DIP-switch 5 to ON (see [Section 8.1](#)).

Note: The device must be power-cycled after you change this DIP-switch.

7.4 Adjusting the UXGA Input Phase

Adjust the phase to get a clean, sharp picture on the screen, with minimal horizontal streaking and shimmering.

To adjust the UXGA input phase:

- Press and hold the Input Select button to increase the phase repetitively by one degree per second
- Press and hold the StepIn button to decrease the phase repetitively by one degree per second

8 Configuring and Maintaining the SID-X1N

8.1 Setting the Configuration DIP-switch

The 8x dip-switch provides the ability to configure a number of device functions. A switch that is down is on, a switch that is up is off. By default, switch 2 is down (on), all the other switches are up (off).

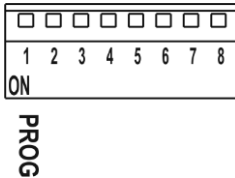

Figure 8: The Configuration DIP-switch

Note: You must power cycle the device if you make any changes to the DIP-switch.

#	Feature	Function	DIP-switch
1	Program	Enables firmware updates	On—Enable updating Off—Disable updating
2	General audio control	Selects whether the analog audio is embedded in the outputs, (see Section 6.2)	On—Use embedded audio for HDMI and DP; the audio selection for DVI is selected by DIP-switch 3 Off—The HDMI, DVI and DP inputs use the analog audio signal if a 3.5mm audio jack is inserted into the analog audio input. If no jack is inserted, they use their embedded audio signals
3	DVI audio control (active only when DIP-switch 2 is on)	Selects whether the analog audio is embedded in the DVI signal	On—When switch #2 is on, the analog audio signal is used with the DVI input Off—When switch #2 is off, the embedded audio signal is used in the DVI input
4	Video mode input selection	Sets the video input selection mode to either last connected or manual, (see Section 6.1)	On—Last connected Off—Manual
5	Lock EDID	Locks the current EDID, (see Section 7.3)	On—Locked EDID Off—Automatic EDID selection

#	Feature	Function	DIP-switch
6	Switching delay	Selects the time delay before switching occurs when an input signal is lost. Note: The delay is independent of the input switching mode	When the input signal is lost but the cable is not removed: On—0.5 seconds Off—10 seconds
			When the cable is removed: On—0.5 seconds Off—3 seconds
7	Output disable delay	Sets the delay time between loss of the input signal and output/PowerConnect shutdown	On—1 minute Off—15 minutes
8	Output Power Control	Enables/disables the output power when the input signal is lost	On—Power is always on Off—Power is disabled when input signal is lost after delay set by DIP-switch 7

Note: DIP-switch 2 must be set to ON to enable DIP-switch 3 to control the DVI audio mode selection.

9 Wiring the Twisted Pair RJ-45 Connectors

When using STP cable, connect/solder the cable shield to the RJ-45 connector shield. [Figure 9](#) defines the TP pinout using a straight pin-to-pin cable with RJ-45 connectors

EIA /TIA 568B	
PIN	Wire Color
1	Orange / White
2	Orange
3	Green / White
4	Blue
5	Blue / White
6	Green
7	Brown / White
8	Brown
Pair 1	4 and 5
Pair 2	1 and 2
Pair 3	3 and 6

Figure 9: TP Pinout Wiring

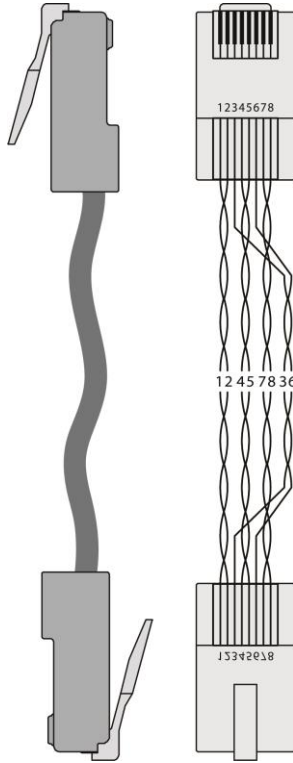

Warning: Using a TP cable that is incorrectly wired will cause permanent damage to the device

10 Technical Specifications

INPUTS:	Video:	1 HDMI on an HDMI connector 1 DP on a DisplayPort connector 1 DVI-D on a DVI-I connector 1 VGA on a 15-pin HD (F) connector
	Audio:	1 Unbalanced stereo audio on a 3.5mm mini jack
OUTPUTS:	1 TP on an RJ-45 1 Unbalanced stereo audio in a 3.5mm mini jack	
PORTS:	1 RS-232 3-pin terminal block for programming	
CONTROLS:	Front panel buttons, remote step-in switch, remote input selection switches, RS-232	
ANALOG AUDIO INPUT:	Maximum level—3Vpp	
REMOTE LED IMPEDANCE:	5V, 300Ω approx.	
STANDARDS:	HDMI with x.v.Color™ and 3D HDCP: Works with sources that support HDCP repeater mode	
MAXIMUM DATA RATE:	4.95Gbps (1.65Gb per graphics channel)	
MAXIMUM STEP-IN DISTANCE:	50m (164ft) up to 1080p @60Hz @24bpp	
POWER CONSUMPTION:	12V DC, 1.1A	
COMPLIANCE STANDARDS:	CE, UL	
OPERATING TEMPERATURE:	0° to +40°C (32° to 104°F)	
STORAGE TEMPERATURE:	-40° to +70°C (-40° to 158°F)	
HUMIDITY:	10% to 90%, RHL non-condensing	
COOLING:	Convection, vents	
ENCLOSURE TYPE:	Aluminium	
DIMENSIONS:	18.8cm x 11.3cm x 2.5cm (7.4" x 4.5" x 1") W, D, H rack-mountable	
WEIGHT:	0.48kg (1.1lbs) approx.	
INCLUDED ACCESSORIES:	Power adapter	
OPTIONS:	19" Rack adapter RK-T2B, RTBUS-12, RTBUS-22, SID-X1NBP Kit (substitute black top plate for the SID-X1N to blend in with the color of the modular TBUS-10xl)	

10.1 Supported Resolutions

HDMI/DVI

Resolution	Refresh Rate
640 x 480p	85Hz; 75Hz; 72Hz; 60Hz; 59.95Hz
720 x 480i	30Hz
720 x 480p	60Hz
720 x 576p	50Hz
848 x 480p	60Hz
852 x 480p	60Hz
800 x 600p	85Hz; 75Hz; 72Hz; 60Hz
1024 x 768p	85Hz; 75Hz; 70Hz; 60Hz
1152 x 864p	75Hz
1280 x 768p	60Hz
1280 x 800p	60Hz
1360 x 768p	60Hz
1366 x 768	60Hz; 50Hz
1280 x 960	60Hz
1280 x 1024p	75Hz; 60Hz
1440 x 900p	60Hz
1400 x 1050p	60Hz
1600 x 900p	60Hz
1680 x 1050p	60Hz
1600 x 1200p	60Hz
1080 x 1920p	50Hz; 60Hz; 24Hz;
1080 x 1920i	50Hz; 60Hz;

DisplayPort

Resolution	Refresh Rate
640 x 480p	85Hz; 75Hz; 72Hz; 60Hz
848 x 480p	60Hz
800 x 600p	85Hz; 75Hz; 72Hz; 60Hz
1024 x 768p	85Hz; 75Hz; 70Hz; 60Hz
1152 x 864p	75Hz
1280 x 768p	60Hz
1280 x 800p	60Hz
1360 x 768p	60Hz
1366 x 768	60Hz;
1280 x 960	60Hz
1280 x 1024p	75Hz; 60Hz
1440 x 900p	60Hz
1400 x 1050	60Hz

Resolution	Refresh Rate
1600 x 900p	60Hz
1680 x 1050p	60Hz
1600 x 1200p	60Hz
1080 x 1920i	60Hz;

VGA

Resolution	Refresh Rate
640 x 480p	60Hz
720 x 480p	60Hz
800 x 600p	60Hz
1024 x 768p	60Hz
1280 x 720p	60Hz; 50Hz
1152 x 864	75Hz
1360 x 768	60Hz;
1366 x 768	60Hz; 50Hz
1280 x 960p	60Hz
1280 x 1024p	60Hz
1440 x 900	60Hz
1400 x 1050	60Hz
1920 x 1080p	60Hz
1920 x 1200	60Hz; 50Hz

11 Default EDID

Each input on the **SID-X1N** is loaded with a factory default EDID.

Note: When the **SID-X1N** is connected to a DVI acceptor, an audio block is added to the EDID.

11.1 HDMI, DisplayPort and DVI

Monitor

Model name..... SID-X1N
Manufacturer..... KMR
Plug and Play ID..... KMR0672
Serial number..... 505-709990100
Manufacture date..... 2011, ISO week 255
Filter driver..... None

EDID revision..... 1.3
Input signal type..... Digital
Color bit depth..... Undefined
Display type..... RGB color
Screen size..... 520 x 320 mm (24.0 in)
Power management..... Standby, Suspend, Active off/sleep
Extension blocs..... 1 (CEA-EXT)

DDC/CI..... n/a

Color characteristics

Default color space..... Non-sRGB
Display gamma..... 2.20
Red chromaticity..... Rx 0.674 - Ry 0.319
Green chromaticity..... Gx 0.188 - Gy 0.706
Blue chromaticity..... Bx 0.148 - By 0.064
White point (default).... Wx 0.313 - Wy 0.329
Additional descriptors... None

Timing characteristics

Horizontal scan range.... 30-83kHz
Vertical scan range..... 56-76Hz
Video bandwidth..... 170MHz
CVT standard..... Not supported
GTF standard..... Not supported
Additional descriptors... None
Preferred timing..... Yes
Native/preferred timing.. 1280x720p at 60Hz (16:10)
Modeline..... "1280x720" 74.250 1280 1390 1430 1650 720 725 730 750 +hsync +vsync

Standard timings supported

720 x 400p at 70Hz - IBM VGA
720 x 400p at 88Hz - IBM XGA2
640 x 480p at 60Hz - IBM VGA
640 x 480p at 67Hz - Apple Mac II
640 x 480p at 72Hz - VESA
640 x 480p at 75Hz - VESA
800 x 600p at 56Hz - VESA
800 x 600p at 60Hz - VESA
800 x 600p at 72Hz - VESA
800 x 600p at 75Hz - VESA
832 x 624p at 75Hz - Apple Mac II
1024 x 768i at 87Hz - IBM
1024 x 768p at 60Hz - VESA
1024 x 768p at 70Hz - VESA
1024 x 768p at 75Hz - VESA
1280 x 1024p at 75Hz - VESA

1152 x 870p at 75Hz - Apple Mac II
1280 x 1024p at 75Hz - VESA STD
1280 x 1024p at 85Hz - VESA STD
1600 x 1200p at 60Hz - VESA STD
1024 x 768p at 85Hz - VESA STD
800 x 600p at 85Hz - VESA STD
640 x 480p at 85Hz - VESA STD
1152 x 864p at 70Hz - VESA STD
1280 x 960p at 60Hz - VESA STD

EIA/CEA-861 Information

Revision number..... 3
IT underscan..... Supported
Basic audio..... Supported
YCbCr 4:4:4..... Supported
YCbCr 4:2:2..... Supported
Native formats..... 1
Detailed timing #1..... 1920x1080p at 60Hz (16:10)
Modeline..... "1920x1080" 148.500 1920 2008 2052 2200 1080 1084 1089 1125 +hsync +vsync
Detailed timing #2..... 1920x1080i at 60Hz (16:10)
Modeline..... "1920x1080i" 74.250 1920 2008 2052 2200 1080 1084 1094 1124 interlace +hsync
+vsync
Detailed timing #3..... 1280x720p at 60Hz (16:10)
Modeline..... "1280x720" 74.250 1280 1390 1430 1650 720 725 730 750 +hsync +vsync
Detailed timing #4..... 720x480p at 60Hz (16:10)
Modeline..... "720x480" 27.000 720 736 798 858 480 489 495 525 -hsync -vsync

CE video identifiers (VICs) - timing/formats supported

1920 x 1080p at 60Hz - HDTV (16:9, 1:1)
1920 x 1080i at 60Hz - HDTV (16:9, 1:1)
1280 x 720p at 60Hz - HDTV (16:9, 1:1) [Native]
720 x 480p at 60Hz - EDTV (16:9, 32:27)
720 x 480p at 60Hz - EDTV (4:3, 8:9)
720 x 480i at 60Hz - Doublescan (16:9, 32:27)
720 x 576i at 50Hz - Doublescan (16:9, 64:45)
640 x 480p at 60Hz - Default (4:3, 1:1)
NB: NTSC refresh rate = (Hz*1000)/1001

CE audio data (formats supported)

LPCM 2-channel, 16/20/24 bit depths at 32/44/48 kHz

CE vendor specific data (VSDb)

IEEE registration number. 0x000C03
CEC physical address..... 1.0.0.0
Maximum TMDS clock..... 165MHz

CE speaker allocation data

Channel configuration.... 2.0
Front left/right..... Yes
Front LFE..... No
Front center..... No
Rear left/right..... No
Rear center..... No
Front left/right center.. No
Rear left/right center... No
Rear LFE..... No

Report information

Date generated..... 06/08/2014
Software revision..... 2.60.0.972
Data source..... File
Operating system..... 6.1.7601.2.Service Pack 1

Raw data

00,FF,FF,FF,FF,FF,FF,FF,00,2D,B2,72,06,02,00,00,00,FF,15,01,03,80,34,20,78,EA,B3,25,AC,51,30,B4,26,
10,50,54,FF,FF,80,81,8F,81,99,A9,40,61,59,45,59,31,59,71,4A,81,40,01,1D,00,72,51,D0,1E,20,6E,28,
55,00,07,44,21,00,00,1E,00,00,00,FF,00,35,30,35,2D,37,30,39,39,39,30,31,30,30,00,00,00,FC,00,53,
49,44,2D,58,32,4E,00,00,00,00,00,00,00,00,FD,00,38,4C,1E,53,11,00,0A,20,20,20,20,20,01,31,
02,03,1B,F1,48,10,05,84,03,02,07,16,01,23,09,07,07,65,03,0C,00,10,00,83,01,00,00,02,3A,80,18,71,
38,2D,40,58,2C,45,00,07,44,21,00,00,1E,01,1D,80,18,71,1C,16,20,58,2C,25,00,07,44,21,00,00,9E,01,
1D,00,72,51,D0,1E,20,6E,28,55,00,07,44,21,00,00,1E,8C,0A,D0,8A,20,E0,2D,10,10,3E,96,00,07,44,21,

11.2 PC-UXGA

Monitor

Model name..... SID-X1N
Manufacturer..... KMR
Plug and Play ID..... KMR0672
Serial number..... 505-709990100
Manufacture date..... 2011, ISO week 255
Filter driver..... None

EDID revision..... 1.3
Input signal type..... Analog 0.700,0.000 (0.7V p-p)
Sync input support..... Separate, Composite, Sync-on-green
Display type..... RGB color
Screen size..... 520 x 320 mm (24.0 in)
Power management..... Standby, Suspend, Active off/sleep
Extension blocs..... None

DDC/CI..... n/a

Color characteristics

Default color space..... sRGB
Display gamma..... 2.20
Red chromaticity..... Rx 0.674 - Ry 0.319
Green chromaticity..... Gx 0.188 - Gy 0.706
Blue chromaticity..... Bx 0.148 - By 0.064
White point (default).... Wx 0.313 - Wy 0.329
Additional descriptors... None

Timing characteristics

Horizontal scan range.... 30-83kHz
Vertical scan range..... 56-76Hz
Video bandwidth..... 170MHz
CVT standard..... Not supported
GTF standard..... Not supported
Additional descriptors... None
Preferred timing..... Yes
Native/preferred timing.. 1280x720p at 60Hz (16:10)
Modeline..... "1280x720" 74.250 1280 1390 1430 1650 720 725 730 750 +hsync +vsync

Standard timings supported

720 x 400p at 70Hz - IBM VGA
720 x 400p at 88Hz - IBM XGA2
640 x 480p at 60Hz - IBM VGA
640 x 480p at 67Hz - Apple Mac II
640 x 480p at 72Hz - VESA
640 x 480p at 75Hz - VESA
800 x 600p at 56Hz - VESA
800 x 600p at 60Hz - VESA
800 x 600p at 72Hz - VESA
800 x 600p at 75Hz - VESA
832 x 624p at 75Hz - Apple Mac II
1024 x 768i at 87Hz - IBM
1024 x 768p at 60Hz - VESA
1024 x 768p at 70Hz - VESA
1024 x 768p at 75Hz - VESA
1280 x 1024p at 75Hz - VESA
1152 x 870p at 75Hz - Apple Mac II
1280 x 1024p at 75Hz - VESA STD
1280 x 1024p at 85Hz - VESA STD
1600 x 1200p at 60Hz - VESA STD
1024 x 768p at 85Hz - VESA STD
800 x 600p at 85Hz - VESA STD
640 x 480p at 85Hz - VESA STD
1152 x 864p at 70Hz - VESA STD
1280 x 960p at 60Hz - VESA STD

Report information

12 Remote Commands

Note: The **SID-X1N** can receive commands over HDMI only from the **VP-81SID**.

This RS-232/RS-485 communication protocol uses four bytes of information as defined below.

For RS-232, a null-modem connection between the machine and controller is used. The default data rate is 9600 baud, with no parity, 8 data bits and 1 stop bit.

12.1 Syntax

MSB				LSB			
1st Byte		DESTINATION		INSTRUCTION			
0	D	N5	N4	N3	N2	N1	N0
7	6	5	4	3	2	1	0
2nd Byte		INPUT					
1	I6	I5	I4	I3	I2	I1	I0
7	6	5	4	3	2	1	0
3rd Byte		OUTPUT					
1	O6	O5	O4	O3	O2	O1	O0
7	6	5	4	3	2	1	0
4th Byte		MACHINE NUMBER					
1	OVR	X	M4	M3	M2	M1	M0
7	6	5	4	3	2	1	0

1st Byte: Bit 7 – Defined as 0
 D – DESTINATION:
 0 – Sends information to the switchers (from the PC)
 1 – Sends information to the PC (from the switcher)
 N5...N0 – INSTRUCTION

The 6-bit INSTRUCTION defines the function performed by the switcher(s). If a function is performed using the machine's keyboard, these bits are set with the INSTRUCTION NO. performed. The instruction codes are defined according to the table below (INSTRUCTION NO. is the value set in N5...N0).

2nd Byte: Bit 7 – Defined as 1
 I6...I0 – INPUT

When switching (i.e. instruction codes 1 and 2), the 7-bit INPUT is set as the input number to be switched. If switching is done using the machine's front panel, these bits are set with the INPUT NUMBER switched. For other operations, these bits are defined according to the table.

3rd Byte: Bit 7 – Defined as 1
 O6...O0 – OUTPUT

When switching (i.e. instruction codes 1 and 2), the 7-bit OUTPUT is set as the output number to be switched. If switching is done using the machine's front panel, these bits are set with the OUTPUT NUMBER switched. For other operations, these bits are defined according to the table.

4th Byte: Bit 7 – Defined as 1
 Bit 5 – Don't care
 OVR – Machine number override
 M4...M0 – MACHINE NUMBER

This byte is used to address machines in a system by their machine numbers. When several machines are controlled from a single serial port, they are usually configured together and each machine has an individual machine number. If the OVR bit is set, then all machine numbers accept (implement) the command and the addressed machine replies. When a single machine is controlled over the serial port, always set M4...M0 to 1, and make sure that the machine itself is configured as MACHINE NUMBER = 1.

12.2 Instruction Codes

All the values in the table are decimal, unless otherwise stated

Instruction Codes for Commands				
Instruction		Definition for Specific Instruction		Notes
#	Description	Input	Output	
0	RESET VIDEO	0	0	1
1	SWITCH VIDEO	Set equal to video input that is switched (0 = disconnect)	Set equal to video output that is switched (0 = to all the outputs)	2, 15
2	SWITCH AUDIO	Set equal to audio input that is switched (0 = disconnect)	Set equal to audio output that is switched (0 = to all the outputs)	2
3	STORE VIDEO STATUS	Set as SETUP #	To store To delete	2, 3, 15
4	RECALL VIDEO STATUS	Set as SETUP #	0	2, 3, 15
5	REQUEST STATUS OF A VIDEO OUTPUT	Set as SETUP #	Equal to output number whose status is required	4, 3
6	REQUEST STATUS OF AN AUDIO OUTPUT	Set as SETUP #	Equal to output number whose status is required	4, 3
7	VIS SOURCE	Set as input # when OUTPUT byte = 6; OR Set as output # when OUTPUT byte = 7; OR Set as blank period (in steps of 25ms) when OUTPUT byte = 32; OR Set = 0. *****	0 – No VIS (immediate) 1 – Input # 1 2 – External digital sync 3 – External analog sync 4 – Dynamic sync 5 – Inter-machine sync 6 – Input # (INPUT byte) 7 – Output # (INPUT byte) 8 – User-defined sync 32 – RGBHV seamless switching 64 – Set for delayed switch 65 – Execute delayed switch 66 – Cancel delayed switch setting	2, 5, 17, 18

NOTES on the above table:

NOTE 2 – These are bi-directional definitions. If the switcher receives the code, it performs the instruction. If the instruction is performed (due to a keystroke operation on the front panel), then these codes are sent. For example, if the PC sends HEX code:

01 85 88 83
then the switcher (machine 3) switches input 5 to output 8.

If the user switches input 1 to output 7 using the front panel buttons, the switcher sends HEX code:

41 81 87 83

to the PC.

When the PC sends one of the commands in this group to the switcher, if the instruction is valid, the switcher replies by sending the same four bytes to the PC that it received (except for the first byte, where the DESTINATION bit is set high).

NOTE 5 – For the OUTPUT byte set as 6, the VIS source is the input selected using the OUTPUT byte. Similarly, for the OUTPUT byte set as 7, the VIS source is the output selected using the OUTPUT byte. Note that on some machines the sync source is not software selectable, but is selected using switches, jumpers, etc.

NOTE 17 – For clean switching of RGBHV video, the seamless switching option can be used. The blanking period for the transition of the RGB sources can be set in steps of 25 milliseconds.

For example, to set for 350ms blanking time (14 steps), send HEX code:

07 8E A0 81.

NOTE 18 – Delayed execution switches after a delay dictated by RS-232 control. To do this, the user sends instruction 7 with the SET FOR DELAYED SWITCH option (64_{dec}) before sending the switch command

(instruction 1) or pressing a front panel button. The switch is not executed (unless timed-out) until the EXECUTE DELAYED SWITCH code is sent, or the SET FOR DELAYED SWITCH code is sent again. (The mode is automatically cancelled after switching if the EXECUTE command is used).
For example, to connect input 4 to output 3 after a delay, send HEX code:
07 80 C0 81 (set for delayed switch)
01 84 83 81 (switch code)
then, after the required delay, send HEX code:
07 80 C1 81(execute delayed switch)
to implement the switch.

The following sources are supported:

HDMI input : 0x07 0x80 0x81 0x81<CR>
DP input : 0x07 0x80 0x85 0x81<CR>
DVI input : 0x07 0x80 0x89 0x81<CR>
VGA input : 0x07 0x80 0x8C 0x81<CR>

LIMITED WARRANTY

The warranty obligations of Kramer Electronics for this product are limited to the terms set forth below:

What is Covered

This limited warranty covers defects in materials and workmanship in this product.

What is Not Covered

This limited warranty does not cover any damage, deterioration or malfunction resulting from any alteration, modification, improper or unreasonable use or maintenance, misuse, abuse, accident, neglect, exposure to excess moisture, fire, improper packing and shipping (such claims must be presented to the carrier), lightning, power surges, or other acts of nature. This limited warranty does not cover any damage, deterioration or malfunction resulting from the installation or removal of this product from any installation, any unauthorized tampering with this product, any repairs attempted by anyone unauthorized by Kramer Electronics to make such repairs, or any other cause which does not relate directly to a defect in materials and/or workmanship of this product. This limited warranty does not cover cartons, equipment enclosures, cables or accessories used in conjunction with this product.

Without limiting any other exclusion herein, Kramer Electronics does not warrant that the product covered hereby, including, without limitation, the technology and/or integrated circuit(s) included in the product, will not become obsolete or that such items are or will remain compatible with any other product or technology with which the product may be used.

How Long Does this Coverage Last

Seven years as of this printing; please check our Web site for the most current and accurate warranty information.

Who is Covered

Only the original purchaser of this product is covered under this limited warranty. This limited warranty is not transferable to subsequent purchasers or owners of this product.

What Kramer Electronics will do

Kramer Electronics will, at its sole option, provide one of the following three remedies to whatever extent it shall deem necessary to satisfy a proper claim under this limited warranty:

1. Elect to repair or facilitate the repair of any defective parts within a reasonable period of time, free of any charge for the necessary parts and labor to complete the repair and restore this product to its proper operating condition. Kramer Electronics will also pay the shipping costs necessary to return this product once the repair is complete.
2. Replace this product with a direct replacement or with a similar product deemed by Kramer Electronics to perform substantially the same function as the original product.
3. Issue a refund of the original purchase price less depreciation to be determined based on the age of the product at the time remedy is sought under this limited warranty.

What Kramer Electronics will not do Under This Limited Warranty

If this product is returned to Kramer Electronics or the authorized dealer from which it was purchased or any other party authorized to repair Kramer Electronics products, this product must be insured during shipment, with the insurance and shipping charges prepaid by you. If this product is returned uninsured, you assume all risks of loss or damage during shipment. Kramer Electronics will not be responsible for any costs related to the removal or re-installation of this product from or into any installation. Kramer Electronics will not be responsible for any costs related to any setting up this product, any adjustment of user controls or any programming required for a specific installation of this product.

How to Obtain a Remedy under this Limited Warranty

To obtain a remedy under this limited warranty, you must contact either the authorized Kramer Electronics reseller from whom you purchased this product or the Kramer Electronics office nearest you. For a list of authorized Kramer Electronics resellers and/or Kramer Electronics authorized service providers, please visit our web site at www.kramerelectronics.com or contact the Kramer Electronics office nearest you.

In order to pursue any remedy under this limited warranty, you must possess an original, dated receipt as proof of purchase from an authorized Kramer Electronics reseller. If this product is returned under this limited warranty, a return authorization number, obtained from Kramer Electronics, will be required. You may also be directed to an authorized reseller or a person authorized by Kramer Electronics to repair the product.

If it is decided that this product should be returned directly to Kramer Electronics, this product should be properly packed, preferably in the original carton, for shipping. Cartons not bearing a return authorization number will be refused.

Limitation on Liability

THE MAXIMUM LIABILITY OF KRAMER ELECTRONICS UNDER THIS LIMITED WARRANTY SHALL NOT EXCEED THE ACTUAL PURCHASE PRICE PAID FOR THE PRODUCT. TO THE MAXIMUM EXTENT PERMITTED BY LAW, KRAMER ELECTRONICS IS NOT RESPONSIBLE FOR DIRECT, SPECIAL, INCIDENTAL OR CONSEQUENTIAL DAMAGES RESULTING FROM ANY BREACH OF WARRANTY OR CONDITION, OR UNDER ANY OTHER LEGAL THEORY. Some countries, districts or states do not allow the exclusion or limitation of relief, special, incidental, consequential or indirect damages, or the limitation of liability to specified amounts, so the above limitations or exclusions may not apply to you.

Exclusive Remedy

TO THE MAXIMUM EXTENT PERMITTED BY LAW, THIS LIMITED WARRANTY AND THE REMEDIES SET FORTH ABOVE ARE EXCLUSIVE AND IN LIEU OF ALL OTHER WARRANTIES, REMEDIES AND CONDITIONS, WHETHER ORAL OR WRITTEN, EXPRESS OR IMPLIED. TO THE MAXIMUM EXTENT PERMITTED BY LAW, KRAMER ELECTRONICS SPECIFICALLY DISCLAIMS ANY AND ALL IMPLIED WARRANTIES, INCLUDING, WITHOUT LIMITATION, WARRANTIES OF MERCHANTABILITY AND FITNESS FOR A PARTICULAR PURPOSE. IF KRAMER ELECTRONICS CANNOT LAWFULLY DISCLAIM OR EXCLUDE IMPLIED WARRANTIES UNDER APPLICABLE LAW, THEN ALL IMPLIED WARRANTIES COVERING THIS PRODUCT, INCLUDING WARRANTIES OF MERCHANTABILITY AND FITNESS FOR A PARTICULAR PURPOSE, SHALL APPLY TO THIS PRODUCT AS PROVIDED UNDER APPLICABLE LAW.

IF ANY PRODUCT TO WHICH THIS LIMITED WARRANTY APPLIES IS A "CONSUMER PRODUCT" UNDER THE MAGNUSON-MOSS WARRANTY ACT (15 U.S.C.A. §2301, ET SEQ.) OR OTHER APPLICABLE LAW, THE FOREGOING DISCLAIMER OF IMPLIED WARRANTIES SHALL NOT APPLY TO YOU, AND ALL IMPLIED WARRANTIES ON THIS PRODUCT, INCLUDING WARRANTIES OF MERCHANTABILITY AND FITNESS FOR THE PARTICULAR PURPOSE, SHALL APPLY AS PROVIDED UNDER APPLICABLE LAW.

Other Conditions

This limited warranty gives you specific legal rights, and you may have other rights which vary from country to country or state to state.

This limited warranty is void if (i) the label bearing the serial number of this product has been removed or defaced, (ii) the product is not distributed by Kramer Electronics or (iii) this product is not purchased from an authorized Kramer Electronics reseller. If you are unsure whether a reseller is an authorized Kramer Electronics reseller, please visit our Web site at www.kramerelectronics.com or contact a Kramer Electronics office from the list at the end of this document.

Your rights under this limited warranty are not diminished if you do not complete and return the product registration form or complete and submit the online product registration form. Kramer Electronics thanks you for purchasing a Kramer Electronics product. We hope it will give you years of satisfaction.



For the latest information on our products and a list of Kramer distributors, visit our Web site where updates to this user manual may be found.

We welcome your questions, comments, and feedback.

Web site: www.kramerelectronics.com

E-mail: info@kramerel.com



SAFETY WARNING

Disconnect the unit from the power supply before opening and servicing



P/N: 2900-300302



Rev: 4