

DMP 128 Plus

12X8 ProDSP™
DIGITAL MATRIX PROCESSORS

Advanced Audio DSP with Quick and
Intuitive Configuration

ProDSP

- ▶ Six models with 12 analog mic/line inputs and 8 analog line outputs
- ▶ All models include a USB Audio interface, providing up to four channels of digital audio sends and returns
- ▶ C Models include AEC on input channels 1–8 with selectable noise cancellation
- ▶ V models include up to 8 VoIP lines that can be configured as individual extensions or for conference calling
- ▶ AT models include 48x24 Dante™ digital audio network expansion capability via an integrated four-port gigabit switch
- ▶ Optional ACP Series audio control panels provide intuitive audio system control



Extron Electronics
INTERFACING, SWITCHING AND CONTROL

Introduction

The Extron DMP 128 Plus series is the next generation of Digital Matrix Processors featuring Extron's exclusive ProDSP™ 64-bit floating point technology. The DMP 128 Plus Series offers a configuration approach to DSP that simplifies mixing, routing, conferencing, and room optimization. Quick and intuitive configuration using the DSP Configurator Software allows the DMP 128 Plus to be installed in very little time, with easy-to-learn adjustments that can be heard in real-time. The DMP 128 Plus is ideal for presentation and conferencing applications in boardrooms, courtrooms, and conference centers.

Each DMP 128 Plus features 12 analog mono mic/line inputs, eight analog outputs, up to four channels of digital audio input and output via USB, up to eight audio file players, an ACP bus for audio control panels, and configurable macros.

- **C models** also include eight independent channels of AEC - acoustic echo cancellation and noise cancellation.
- **V models** include up to eight channels of VoIP, supporting Session Initiation Protocol - SIP 2.0.
- **AT models** provide Dante audio networking technology with connectivity for an additional 48 digital audio inputs, and 24 digital audio outputs.

Flexible Routing Within the DMP 128 Plus

The DMP 128 Plus and DMP 128 Plus C feature a 52x44 mix matrix allowing all analog inputs, aux inputs, expansion bus inputs and virtual bus returns to be discretely routed to any or all of the analog outputs, aux outputs, expansion bus outputs and the virtual bus sends. The DMP 128 Plus C V features a 52x48 mix matrix and additional aux outputs to allow for VoIP routing.

The DMP 128 Plus AT and DMP 128 Plus C AT feature an 84x44 mix matrix allowing all analog inputs, aux inputs, Dante inputs and

virtual bus returns to be discretely routed to any or all of the analog outputs, aux outputs, Dante outputs and the virtual bus sends. The DMP 128 Plus C V AT expands the mix matrix to 84x48, and the aux output count, for VoIP routing.

Expanded Routing Across Two DMP 128 Plus Processors

The DMP EXP expansion port allows two DMP 128 Plus units to be linked together via a single shielded CAT 6 cable. This creates a 16 channel bi-directional 24-bit/48 kHz high-resolution digital audio expansion bus between the two units, allowing expanded input and output signal management and routing capabilities. This same expansion port can be found on Extron's DTP CrossPoint 4K series, allowing them to be linked to the DMP 128 Plus.

Dante Audio Networking

Dante-equipped DMP 128 Plus AT models provide scalable audio transport over a local area network using standard Internet protocols. Each DMP 128 Plus AT sends out 24 channels of digital audio and can receive 48 channels over the network. A built-in four-port Gigabit switch also provides direct interconnection of multiple DMP 128 Plus AT processors, AXP Series expansion processors, and AXI Series Dante interfaces to create larger, more cost-effective audio matrixes. Additionally, the DMP 128 Plus AT can be configured to support primary and redundant Dante audio networks.

FlexInput Capability for Dante Inputs

DMP 128 Plus AT models include FlexInputs to provide the additional capability of processing Dante channels from remote wireless microphones, wallplates, and other sources on the Dante network, in place of local mic/line inputs 1 - 8. This allows the full range of DSP processing capabilities, including AEC - Acoustic Echo Cancellation, to be implemented on incoming Dante channels.

Automixer

The DMP 128 Plus features an automixer with gated and gain sharing modes for managing up to eight groups of microphones. Gating threshold, signal level reduction, and timing parameters are user-adjustable per channel. This allows for fine-tuning to avoid the "chopped" sound of a traditional automixer when a mic is gated off.

Acoustic Echo Cancellation

Extron AEC features advanced algorithms that deliver fast echo canceler convergence for optimal intelligibility in challenging conditions such as double-talk and the use of wireless microphones. The DMP 128 Plus C models include eight independent channels of high performance AEC, as well as selectable noise cancellation.





The DMP 128 Plus features Extron ProDSP, a powerful digital signal processing platform

based on a 64-bit floating point DSP engine. ProDSP provides an extensive array of digital processing tools for audio system design, configuration, and optimization. The DSP Configurator Software is the user interface to ProDSP for full control and management of the DMP 128 Plus and all of its DSP functions, including gain, filtering, dynamics, delay, ducking, loudness, and feedback suppression. DSP Configurator Software is also used to configure and manage AEC and automixing. An integral part of the DSP Configurator Software is the Graphical User Environment, which allows for quick and easy visualization of all signal paths inside a single window. Working within this user-friendly environment, an audio system designer or installer can clearly view and adjust all input levels, audio DSP processing parameters, mixing points, and output levels. To simplify these adjustments, SpeedNav™ keyboard navigation ensures efficient and fast navigation through the Graphical User Environment, using just the keyboard on a laptop.

Highest Quality Converters Plus Floating Point DSP

The DMP 128 Plus features studio grade ADCs - analog-to-digital converters and DACs - digital-to-analog converters using professional level 24-bit resolution and 48 kHz sampling, fully preserving the integrity of the original audio signal. The processing power of the 64-bit floating point DSP engine allows for simultaneous audio processing algorithms within the same channel and across multiple channels, without compromising sound quality. Throughput latency – the normal delay of audio signals due to audio processing – is deterministic with very low overall latency, regardless of the number of channels and processes, so that audio is kept in sync with video. This powerful DSP engine also delivers very wide dynamic range to prevent clipping and fully maintain signal quality.

Fixed Yet Flexible DSP Architecture

The DSP Configurator Software uses DSP processing blocks for each input, output, and virtual bus. Each processing block represents a Gain, Dynamics, Delay, Filter, Ducking, or FBS - Feedback Suppression algorithm within the DSP engine. While this architecture is fixed, each block offers flexible options and customizable parameters. For example, the Filter block contains several selectable filters, each of which can be customized as high pass, low pass, bass and treble, or parametric EQ. Each processing block can be selectively bypassed.

Emulate and Live Modes

The DSP Configurator Software features an Emulate mode, which provides complete audio system design while working offline on a PC. When connected to the DMP 128 Plus, Live mode enables realtime control of all settings, file updates, and archiving, plus active metering of all input and output channels. In Live mode, integrators can “push” all or part of a configuration to the DMP 128 Plus from the PC, while preserving the existing file. Emulate and Live modes give audio system designers the flexibility to create an entire project from their PC in advance of installation, and then, once they are on-site, use the same software to provide accurate system setup and final optimization.

EXTENSIVE ARRAY OF DSP TOOLS

GAIN STAGES	Input PreMatrix Matrix Output Trim Output	(+80/-18 dB, Mute, 48V, Polarity) (+12/-100 dB, Mute) (+12/-100 dB, Mute) (+12/-12 dB) (+0/-100 dB, Mute)
FILTERS	Parametric EQ Notch EQ High Pass Butterworth Low Pass Butterworth High Pass Bessel Low Pass Bessel High Pass Linkwitz-Riley Low Pass Linkwitz-Riley Treble Shelving Bass Shelving	(±24 dB, Q: 0.5-30) (+0/-30 dB, Q: 1-65) (6-48 dB/Oct) (6-48 dB/Oct) (6-48 dB/Oct) (6-48 dB/Oct) (12-48 dB/Oct) (12-48 dB/Oct) (±24 dB, 6-48 dB/Oct) (±24 dB, 6-48 dB/Oct)
DYNAMICS	AGC - automatic gain control Compressor Limiter Noise gate	
DELAY	Up to 200 ms Resolution of 0.021 ms (1 sample)	
DUCKING	Signal at input initiates multiple priority level ducking of any or all other inputs and virtual returns	
ADAPTIVE GAIN	Signal at input initiates gain on any one or all other inputs and virtual returns	
AEC	8 independent acoustic echo cancellers with selectable noise reduction	
AUTOMIXING	8 gating or gain sharing automixer groups Available on all analog and digital inputs	
FEEDBACK SUPPRESSION	15 dynamic and 5 fixed notch filters Notch EQ (+0/-30 dB, Q: 1-65)	
PRESETS	32 presets store entire DSP configurations or selected DSP settings	

Extron ProDSP includes all the essential DSP tools needed to set up and fine-tune audio systems. These tools, or processing blocks, allow for control and management of gain, dynamics, filtering, delay, ducking, and feedback suppression. Input and output levels can be monitored at any time by simply opening any of the input or output Gain or Attenuation dialogs.

Key Features

ASSIGNABLE AUX INPUTS & OUTPUTS

New for the DMP 128 Plus Series, eight Aux input channels can be individually allocated for Audio File Playback, USB Audio, or VoIP lines (V models only). All Aux inputs and outputs are discretely assignable to and from the mix matrix, making them an extraordinarily powerful feature.

AUDIO FILE PLAYBACK

Eight audio file players are available that allow the user to play one of the test tone files shipped with the DMP 128 Plus or a user imported file. Compatible file formats include WAV, AIFF and MP3 up to 32-bit, 384 kHz. All imported files are converted to RAW mono 16-bit, 48 kHz and are stored on the DMP 128 Plus. Up to 20 minutes of audio file storage is available.

Players can be set for single play or repeat. Users can manually start players as a means to test the system, such as a sine wave for setting gain structure or pink noise for acoustic tests.

Players can also be remotely initiated for messaging or other applications. In such a case, the player would be set for single play.

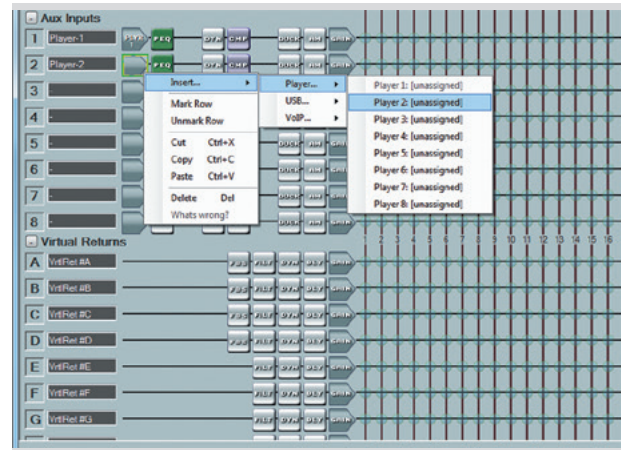

USB AUDIO INTERFACE

The rear panel USB port provides a 4x4 channel USB audio interface to a host PC, using either Mac or PC drivers. The USB audio channels are individually assignable to any of the Aux channel input and output busses dedicated to USB/VoIP/file player functionality. The available bit-depth/sample rate is 16-Bit/48 kHz. An LED indicator on the front panel illuminates when a USB signal is active.

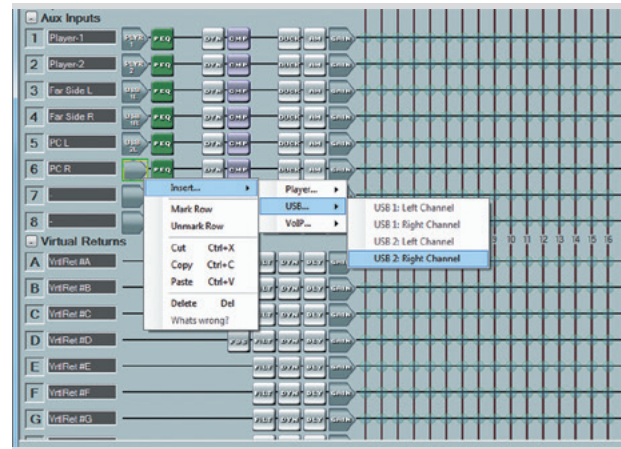

VOIP INTERFACE

DMP 128 Plus C V and DMP 128 Plus C V AT models include up to eight VoIP lines, with wideband codec support, that can be configured as individual extensions or with multiple call appearance channels to support local conferencing applications. Network-specific VoIP configuration such as call server registration, VLAN provisioning, QoS, and NAT Traversal, is managed through a dedicated VoIP configuration webpage, where SIP transaction log and advanced diagnostic tools are also available. This segregation of VoIP configuration allows IT and network administrators to effectively manage the VoIP aspect of DMP 128 Plus devices without the need to develop a detailed knowledge of audio DSP configuration. Compatible with a majority of existing VoIP systems, any V model of the DMP 128 Plus Series can be used for a single VoIP line or as a VoIP farm for up to eight rooms.

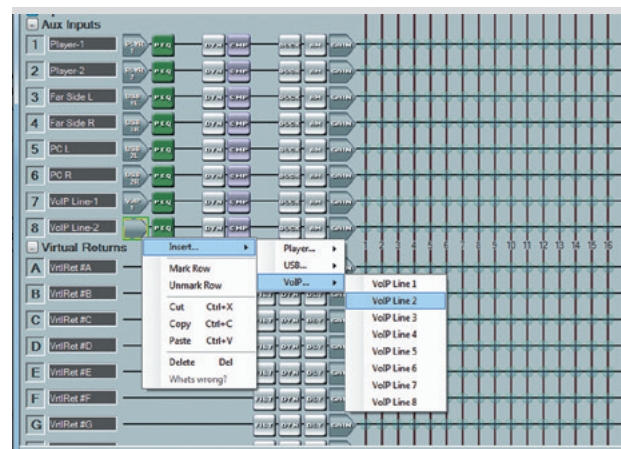

EXTENSIVE MIX MATRIX AND FLEXIBLE ROUTING

The DMP 128 Plus and DMP 128 Plus C feature a 52x44 mix matrix allowing all analog inputs, aux inputs, expansion bus inputs and virtual bus returns to be discretely routed to any or all of the analog outputs, aux outputs, expansion bus outputs and the virtual bus sends. The DMP 128 Plus C V features a 52x48 mix matrix, which includes additional aux outputs to allow for VoIP routing.

The DMP 128 Plus AT and DMP 128 Plus C AT feature an even larger 84x44 mix matrix allowing all analog inputs, aux inputs, Dante inputs and virtual bus returns to be discretely routed to any or all of the analog outputs, aux outputs, Dante outputs and the virtual bus sends. The DMP 128 Plus C V AT expands the mix matrix to 84x48, and the aux output count, for VoIP routing.

PROGRAMMABLE MACROS

A macro is a sequence of commands that can be initiated using either the DSP Configurator, an ACP series panel, or a set of SIS commands from a control system. Each DMP 128 Plus series device provides 64 macros, each capable of storing 32 commands. Multi-device macros allow for each command to be executed either locally or to an external device such as another DMP 128 Plus or a DTP CrossPoint. This creates a single control point between the Audio DSP system and the control system.

While presets offer the ability to take a snapshot of all or a portion of the DSP, macros can affect relative changes on individual controls, and sequence them in a strategic manner. Macros are created and saved on the device using the Macro Editor in DSP Configurator. Possible macro actions include: Recall Preset, Set Group Gain, Group Gain Inc/Dec, Set Group Mute, Gain, Mute, Set Phantom Power, Meters On/Off & SIS Command.

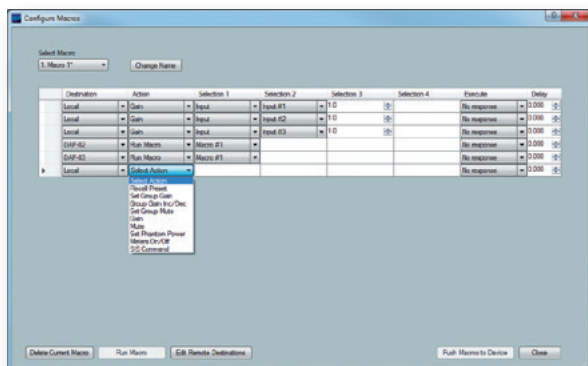

Programmable macros are created and saved on the processor using the Macro Editor in DSP Configurator software.

The DMP 128 Plus supports extensive mix matrixing.

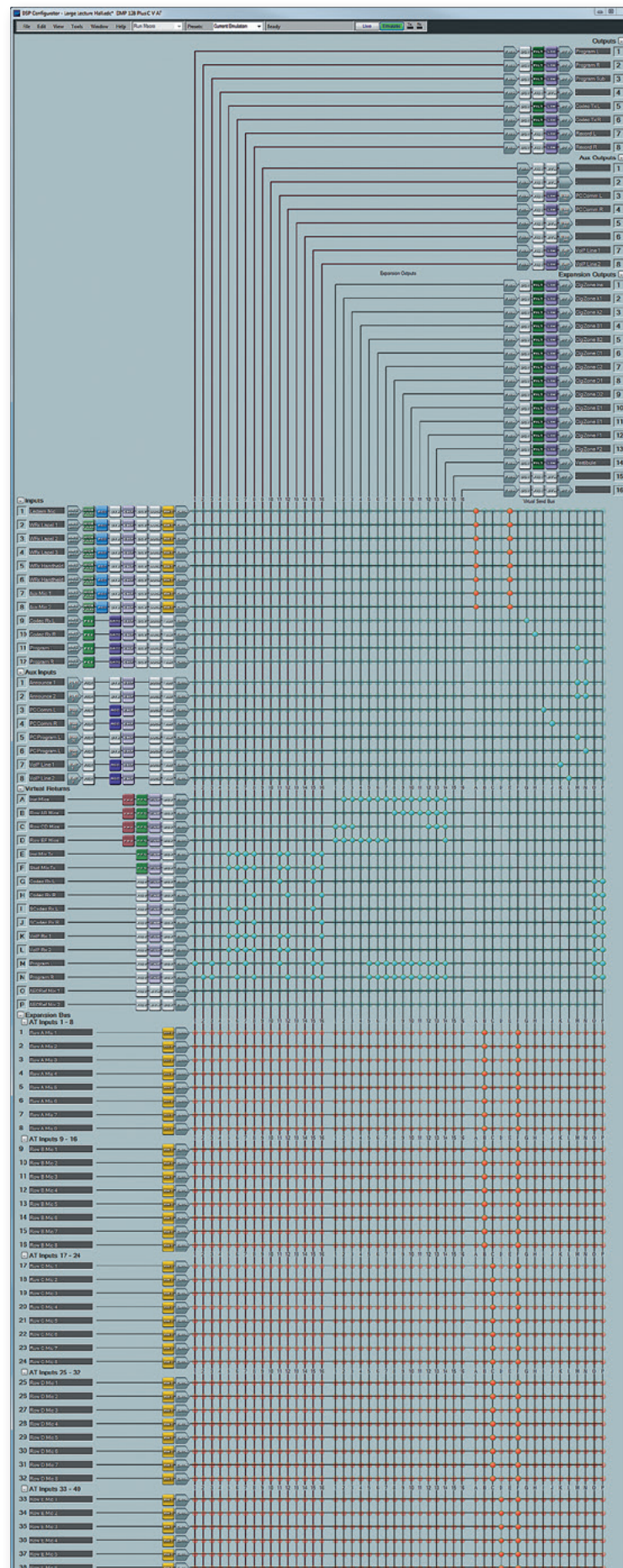

Key Features

DIGITAL AUDIO EXPANSION PORT

The DMP EXP digital audio expansion port allows two DMP 128 Plus units to be linked together via a single shielded CAT 6 cable. This creates a 16 channel bi-directional 24-bit/48 kHz high-resolution digital audio expansion bus between the two units, allowing expanded input and output signal management and routing capabilities. This expanded 16x16 I/O channel transport between devices allows designers to create audio mixes with advanced I/O and signal management scenarios combining the capabilities of two DMP 128 Plus processors. The expansion port is also available on Extron DTP CrossPoint® matrix switchers. This allows a 16x16 I/O channel transport between the DTP CrossPoint matrix switcher and the DMP 128 Plus to expand the number of available audio inputs for a DTP System, and to add new DSP capabilities, such as automixer, AEC, and VoIP depending on the specific DMP 128 Plus model.

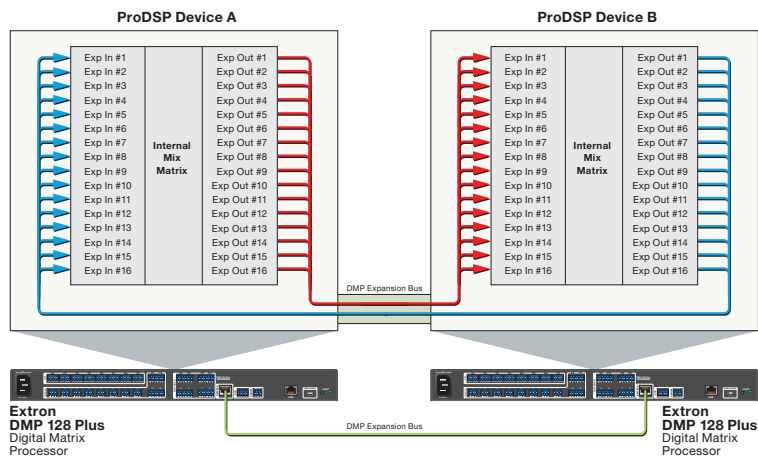

AUTOMIXER

The DMP 128 Plus offers an automixer with gated and gain sharing modes that can manage up to eight groups of microphone signals. Multiple trigger protection allows only the microphone with the highest signal level to be active while the rest are gated off. Gating threshold, signal level reduction, and timing parameters are user adjustable per channel.

An Automix Group dialog enables fast, intuitive management of all microphones and groups in a centralized user interface. Here, global and individual adjustments are made to the group, gate status can be viewed, and NOM - number of open microphones - can be specified to limit the number of microphones active at one time.

For a natural sounding mic mix, the automixer also offers a gain sharing mode that allows all mics to gate on, while the gain for the mic group is adjusted in real time to ensure a constant system gain.

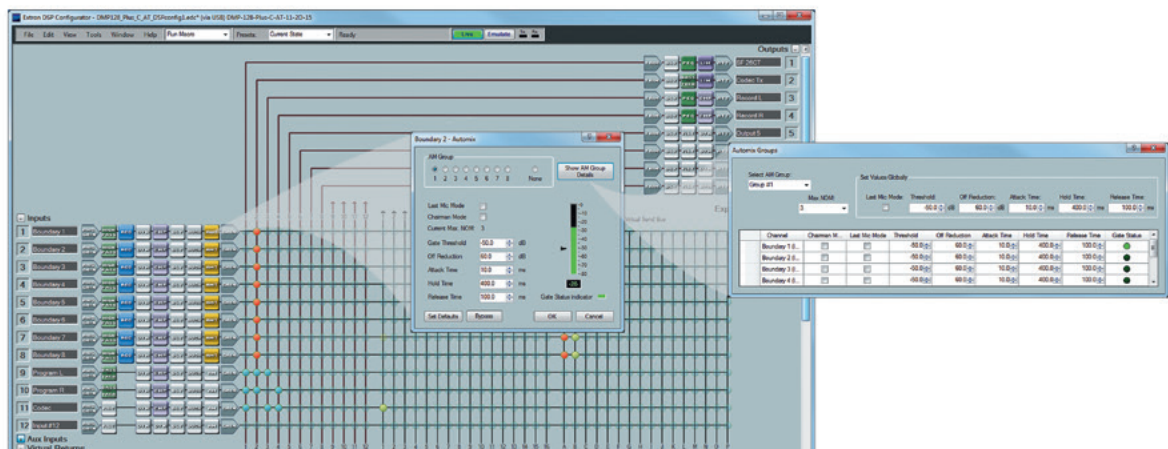

ACOUSTIC ECHO CANCELLATION

Extron AEC features advanced algorithms that deliver fast echo canceler convergence for optimal intelligibility in situations that challenge AEC performance, including double talk, and the use of wireless microphones at the near end. Select DMP 128 Plus models include eight independent channels of high performance AEC, as well as selectable noise cancellation. AEC is essential for effective remote room-to-room conversations, ensuring clear, natural communication for all participants.

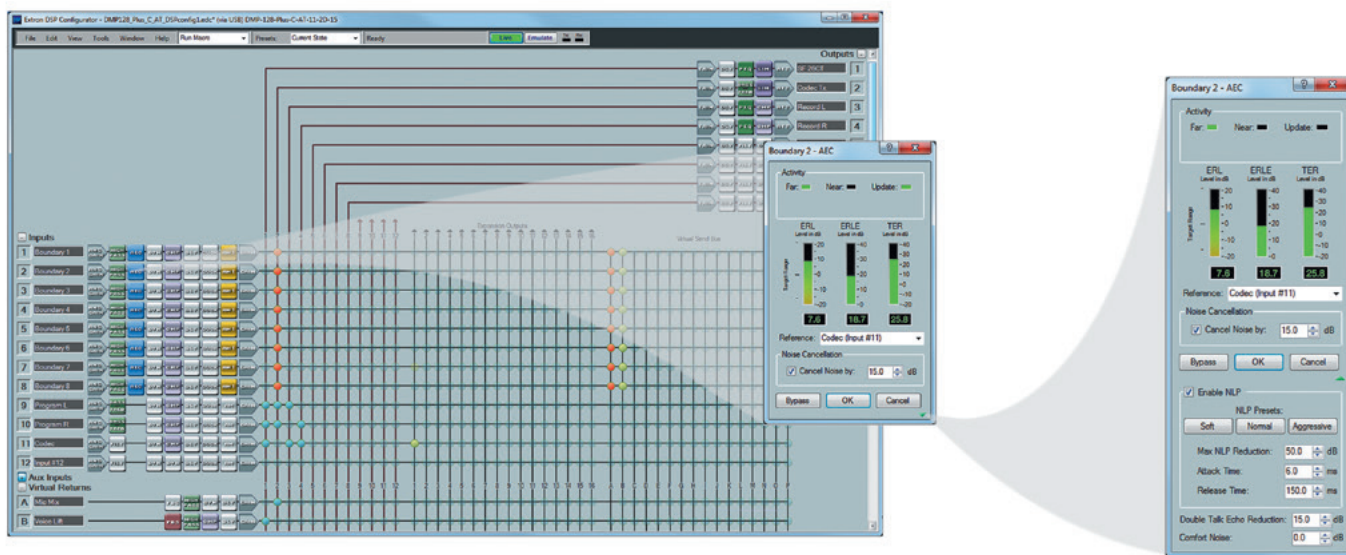

The DSP Configurator Software simplifies AEC and noise cancellation setup with a user-friendly interface that provides real-time metering for ERL - echo return loss, ERLE - echo return loss enhancement, and TER - total echo reduction levels. Guided alerts appear whenever ERL is outside of the optimal range for echo cancellation. Optional settings include fine adjustments for NLP - non-linear processing to maximize AEC performance in acoustic environments with significant sonic reflections or reverberation.

AEC Dialog Close-Up
An AEC reference can be individually selected for each of the eight independent AEC processors within the two DMP 128 Plus C models.

Selecting the AEC Reference

Audio from the far end is reproduced by near end loudspeakers so that listeners can hear the far end talkers. However, this audio can return to the far end via the near end mics, DSP, and codec. To prevent this, AEC processing in the near end analyzes two important signals, the far end audio coming from the conferencing codec or phone input – also known as the AEC reference, and the same audio after being played over the near end speakers into the acoustic space and picked up by the mics. These two signals are analyzed in order to create and apply an adaptive filter to cancel out the far end audio captured at the mic.

The DMP 128 Plus C models provide the flexibility to select the AEC reference signal at any input, output, or virtual return bus. The AEC reference can be independently selected for each of the eight channels of AEC processing.

Model Summary

All models of the DMP 128 Plus Series processors are equipped with 12 analog mic/line inputs, eight analog outputs, a 4x4 USB digital audio interface, and up to eight audio file players. Configurable multi-device macros greatly enhance flexibility in controlling the DMP 128 Plus from a control system. All DMP 128 Plus units have an ACP port will connect to one or more ACP Series audio control panels.



DMP 128 Plus
12x8 ProDSP™ Digital Matrix Processor



DMP 128 Plus AT
12x8 ProDSP™ Digital Matrix Processor with Dante

- Dante audio networking for a wide range of expansion capabilities

Model	Version Description	Part Number	Model	Version Description	Part Number
DMP 128 Plus	12x8 ProDSP Processor	60-1511-01	DMP 128 Plus AT	12x8 ProDSP Processor w/Dante	60-1511-10



DMP 128 Plus C
12x8 ProDSP™ Digital Matrix Processor with AEC

- Eight channels of AEC - acoustic echo cancellation



DMP 128 Plus C AT
12x8 ProDSP™ Digital Matrix Processor with AEC and Dante

- Eight channels of AEC - acoustic echo cancellation
- Dante audio networking for a wide range of expansion capabilities

Model	Version Description	Part Number	Model	Version Description	Part Number
DMP 128 Plus C	12x8 ProDSP Processor w/AEC	60-1512-01	DMP 128 Plus C AT	12x8 ProDSP Processor w/AEC, and Dante	60-1512-10



DMP 128 Plus C V
12x8 ProDSP™ Digital Matrix Processor with AEC and VoIP

- Eight channels of AEC - acoustic echo cancellation
- Up to eight VoIP lines that can support generic SIP 2.0 - RFC 3261
- VoIP configuration via onboard web page separates AV and IT workflows



DMP 128 Plus C V AT
12x8 ProDSP™ Digital Matrix Processor with AEC, VoIP, and Dante

- Eight channels of AEC - acoustic echo cancellation
- Up to eight VoIP lines that can support generic SIP 2.0 - RFC 3261
- VoIP configuration via onboard web page separates AV and IT workflows
- Dante audio networking for a wide range of expansion capabilities

Model	Version Description	Part Number	Model	Version Description	Part Number
DMP 128 Plus C V	12x8 ProDSP Processor w/AEC, and VoIP	60-1513-01	DMP 128 Plus C V AT	12x8 ProDSP Processor w/AEC, VoIP and Dante	60-1513-10

Overview

Front Panel USB Port

Enables easy configuration without having to access the rear panel

Activity LEDs

Provide visual confirmation of signal activity for expansion, LAN, USB Audio ports

Status LEDs

Real-time monitoring of signal presence and clip warning

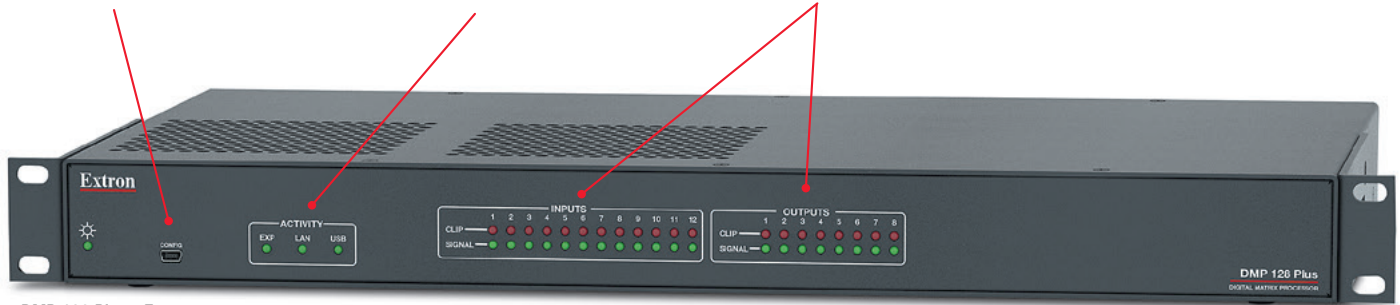

DMP 128 Plus - Front

Control and Feedback via Digital I/O's

Eight input ports and sixteen output ports to sense and then respond to external triggers such as mic activation, muting and recall of presets

Line Level Outputs

Eight balanced or unbalanced line level outputs

ACP Port

Connect up to four Extron Audio Control Panels for direct control of the DMP 128 Plus

Ethernet Port

Gigabit Ethernet connection for configuring DMP 128 Plus using DSP Configurator Software. Enables control and proactive monitoring over a LAN, WAN, or the Internet

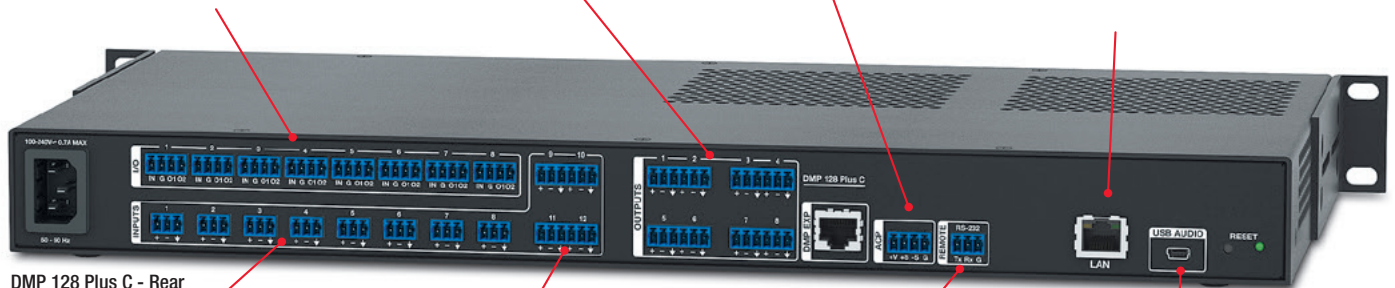

DMP 128 Plus C - Rear

Mic/Line Inputs 1-8

Eight balanced or unbalanced mic/line level inputs with switchable phantom power. Inputs 1-8 used for AEC-C models only

Mic/Line Inputs 9-12

Four balanced or unbalanced mic/line inputs on 6-pole captive screw connectors which support Extron CSR 6 or CSM 6 cable adapters

RS-232 Port

Supports integration with a control system using serial commands

USB Audio Port

USB Audio interface provides up to four channels of digital audio sends and returns

Built In Four-Port Gigabit Ethernet Switch

AT models include a four-port switch that carries Dante audio. Redundant mode is also supported allowing a two-port switch for primary and a two-port switch for secondary

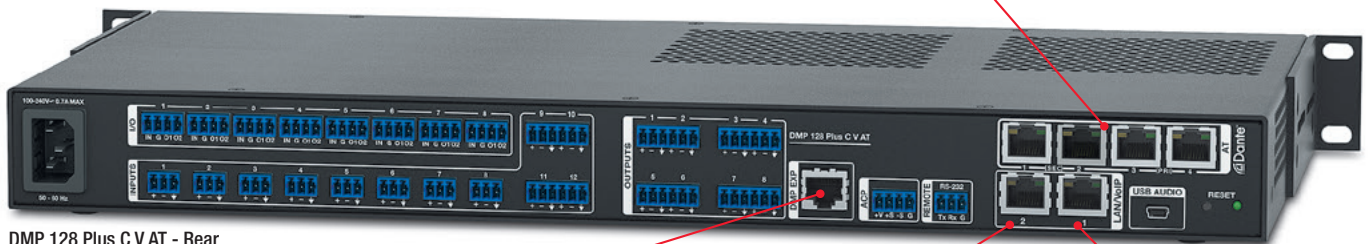

DMP 128 Plus C V AT - Rear

DMP Expansion Port

Used to link another DMP 128 Plus or an Extron DTP Crosspoint unit for greater system expansion

Ethernet Port #2

Gigabit Ethernet connection enables VoIP, control and/or proactive monitoring over a LAN, WAN, or the internet. Default setting is VoIP

Ethernet Port #1

Gigabit Ethernet connection for configuring DMP 128 Plus using DSP Configurator Software. Enables VoIP, control and/or proactive monitoring over a LAN, WAN, or the Internet. Default setting is control

Features

Powerful Floating Point Audio DSP Engine

The DMP 128 Plus features 64-bit floating point audio DSP processing, which maintains very wide dynamic range and audio signal transparency to simplify management of gain staging, while reducing the possibility of DSP signal clipping.

Low Latency DSP Processing

The DMP 128 Plus features very low, deterministic latency from input to output, regardless of the number of active channels or processes. While latency increases in channels with AEC enabled, and marginally with the automixer, overall latency remains low. This keeps audio in sync with video, and prevents distractions to presenters or performers resulting from delayed live audio.

DSP Configurator™ Software

A powerful yet user friendly PC based software tool for managing all audio operations of the DMP 128 Plus. It enables complete setup and configuration of digital audio processing tools on the ProDSP platform, as well as routing and mixing.

Intuitive Graphical User Environment

The DSP Configurator Software features a Graphical User Environment that offers a clear view of all inputs and outputs, audio processing blocks, routing, mix points, and virtual routing in a single window. This allows a designer or installer to quickly view an audio configuration without having to access multiple windows or menus.

Live and Emulate Operation Modes

Live mode allows integrators to connect to the DMP 128 Plus and make live parameter adjustments while hearing or metering them in real time. This avoids the need to compile and upload a configuration file to the DSP. Emulate mode allows settings to be configured offline, then uploaded to the DMP 128. Additionally, current settings on a DMP 128 can be backed up to a configuration file for archiving.

SpeedNav™ Keyboard Navigation

SpeedNav enables user friendly, keyboard based navigation of the DSP Configurator Software without the need for a mouse or touchpad. Using keyboard navigation keys and shortcuts, the user can access any input or output, mix point, and all audio DSP tools. Using only the keyboard for software access can help expedite on site workflows while using laptop PCs.

Copy and Paste for Processing Blocks

To help speed audio system design and setup, parameter settings can be quickly copied between individual processing blocks or identical groups of blocks within the Graphical User Environment, using conventional cut-and-paste commands.

Building Blocks

DSP Configurator Software features a set of graphical Building Blocks which represent processor settings optimized for a specific type of input or output device, such as microphones and Extron speakers, with preset levels, filters, dynamics, and more. Flexible Building Blocks are available on each I/O strip and allow system designers to fully customize and save their own Building Blocks, further streamlining audio system design and integration.

Device Manager

Device Manager in the DSP Configurator Software enables easy configuration of multiple Extron DSP products, including linked or networked DMP 128 Plus processors, by toggling between Graphical User Environments for each unit. Processors can be grouped into folders for organizing as separate rooms or buildings. Settings for multiple Extron DSP products in Device Manager can be saved to a single file.

USB Audio Interface

All models include a USB Audio interface, providing up to four channels of digital audio sends and returns. Support for USB Audio simplifies implementation of systems with either soft-codec conferencing or computer-based audio and enables use of the same interface for both small and large scale systems.

Up to Eight VoIP Lines

The DMP 128 Plus C V and DMP 128 Plus C V AT models include up to eight VoIP lines that can be configured as individual extensions or with multiple call appearance channels to support local conferencing applications. Any single V model of the DMP 128 Plus Series can be used for a single VoIP line or as a VoIP farm for up to eight rooms.

ACP - Audio Control Panels

Optional ACP Panels interface directly with the DMP 128 Plus to provide flexible and economical audio control for systems that do not require a full control system.

Programmable Macros

64 programmable macros allow the sequencing of commands that can be sent to the local device or external devices via the LAN port. A single DMP 128 Plus can act as the central interface from a control system, sending commands to other DMP 128 Plus and DTP CrossPoint units.

Configurable Aux Inputs and Outputs

Each of the Aux inputs and Aux outputs can be individually configured as USB Audio, audio file player, or in V models, VoIP.

Extensive Mix Matrixing

The DMP 128 Plus and DMP 128 Plus C models feature an extensive 52x44 mix matrix allowing all 12 analog inputs, 8 aux inputs, 16 expansion bus inputs and 16 virtual bus returns to be discretely routed to any or all of the 8 analog outputs, 4 aux outputs, 16 expansion bus outputs and the 16 virtual bus sends. The DMP 128 Plus C V model features a 52x48 mix matrix and 4 additional aux outputs to allow for routing of VoIP channels.

The DMP 128 Plus AT and DMP 128 Plus C AT models feature an even larger 84x44 mix matrix allowing all 12 analog inputs, 8 aux inputs, 48 Dante inputs and 16 virtual bus returns to be discretely routed to any or all of the 8 analog outputs, 4 aux outputs, 16 Dante outputs and the 16 virtual bus sends. The DMP 128 Plus C V AT model expands the mix matrix to 84x48, and the aux output count to 8, for VoIP routing.

Adaptive Gain Processor

A new adaptive gain processor block allows a given microphone input to automatically adjust levels on any one or all other inputs and virtual returns.

Audio File Players

Up to eight Audio File Players can be used to play back audio files for system set-up or as part of the system design. WAV, AIFF and MP3 audio files up to 32-bit 384 kHz can be imported into each DMP 128 Plus with room for up to 20 total minutes of audio.

Digital I/O Ports

8 digital input ports and 16 digital output ports are provided, so that the DMP 128 Plus can be programmed to sense and then respond to external triggers such as mic activation, muting, and recall of presets.

Flexible Control Options

The DMP 128 Plus can be controlled using the DSP Configurator Software and a PC connection to the Ethernet port, the RS-232 serial port, or the USB 2.0 port on the front panel. The DMP 128 Plus can also be controlled through a control system with Extron SIS™ - Simple Instruction Set commands.

Group Masters

The DMP 128 Plus provides the capability to consolidate gain or mute control throughout the system. Gain or mute controls can be selected and added to a group master, which can then be controlled by a single master fader or mute control. Each group master can have up to 128 members, and up to 64 group masters can be created.

Soft Limits Provide Optimal Group Master Adjustment Range

The group master volume range can be limited using soft limits to maintain optimal minimum and maximum levels when using external volume control. This prevents operators from over or under-adjusting levels when using digital I/O, RS-232 or Telnet control. The DSP Configurator Software provides quick drag-and-drop adjustment of soft limits from the Group Controls screen.

32 DSP Configurator Presets

Using the DSP Configurator Software, any parameters for DSP processing, levels, or audio routing can be saved as presets. These settings can be saved for the entire system, or any selected group of inputs, outputs, mix points, and DSP blocks.

AEC - Acoustic Echo Cancellation

All C models of the DMP 128 Plus include eight independent channels of high performance AEC, as well as selectable noise cancellation. Extron AEC features advanced algorithms that deliver fast echo canceler convergence for optimal intelligibility in situations that challenge AEC performance, including double talk and the use of wireless microphones at the near end.

Inputs with FlexInput Capability

Eight inputs can be configured for either analog or Dante signals. This provides the option to route either a local mic/line input or a Dante input through the processor for remote wireless mics, wallplates, and sources located anywhere on the Dante network to be brought into the DMP 128 Plus AT.

DMP Expansion Port

An expansion port allows any two DMP 128 Plus models to be linked together via a single shielded CAT 6 cable. This creates a 16 channel bi-directional 24-bit/48 kHz high-resolution digital audio expansion bus between the two units, allowing expanded input and output signal management and routing capabilities. The expansion port is also compatible with Extron DTP CrossPoint matrix switchers for a 16x16 I/O channel transport between devices. A 1 foot (0.3 m) shielded CAT 6 cable is included.

Automixer with eight groups

The DMP 128 Plus features an automixer with gated and gain sharing modes for managing up to eight groups of microphone signals. Gating threshold, signal level reduction, and timing parameters are user adjustable per channel, allowing for fine tuning to avoid the “chopped” sound characteristic of a traditional automixer when a mic is gated off.

48 volt phantom power

The DMP 128 Plus is equipped with selectable 48 volt phantom power for the first eight inputs, allowing the use of condenser microphones.

Studio grade 24 bit/48kHz analog to digital and digital to analog converters

Professional converters fully preserve the integrity of the original audio signal.



DSP Configurator

EASY-TO-USE DSP CONFIGURATOR SOFTWARE FOR FAST SETUP

The DSP Configurator Software features a Graphical User Environment that offers a clear view of all input and outputs, audio processing blocks, and mix points for output, virtual, and expansion bus routing in a single window. This allows a designer or installer to quickly view the entire configuration without having to access multiple windows or menus. The system view can easily be customized by hiding or collapsing sections of the Graphical User Environment, including aux inputs and outputs, virtual buses, and expansion buses. Individual channels can also be hidden from view.

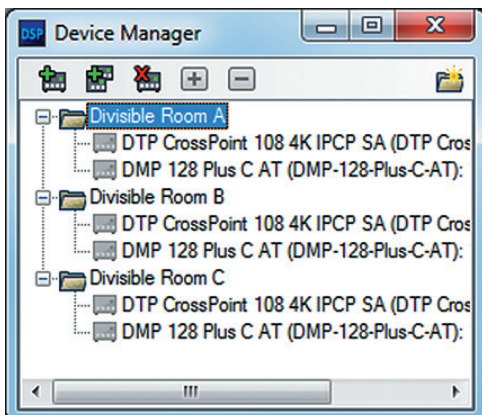
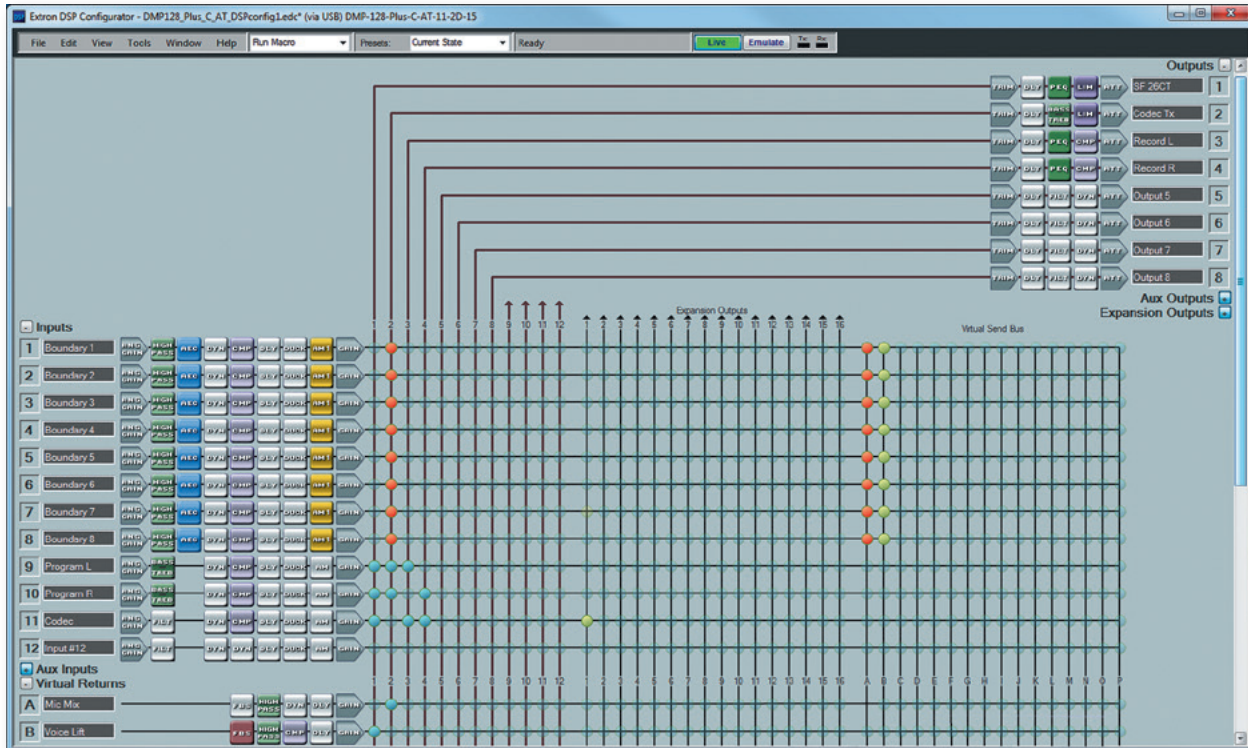

DEVICE MANAGER

Projects with multiple devices can be handled with ease using Device Manager. Navigating from device to device or from room system to room system can be done with just a click. New devices can be added or existing devices can be cloned. A user can import a DSP Configurator file and bring all devices and settings from that file into the Device Manager.

DSP TEMPLATES

An Extron DSP Template is a DSP configuration file that comes preconfigured with AEC, automixing, matrix routing, expansion bus routing and control, all for the selected system hardware. Used alone or in combination with DSP Configurator's included Building Blocks, Extron DSP Templates are available as starting points to facilitate and simplify system configuration. DSP Templates are available for all ProDSP products including the digital matrix processors - DMP, audio expansion processors - AXP, and DTP CrossPoint Matrix switchers.

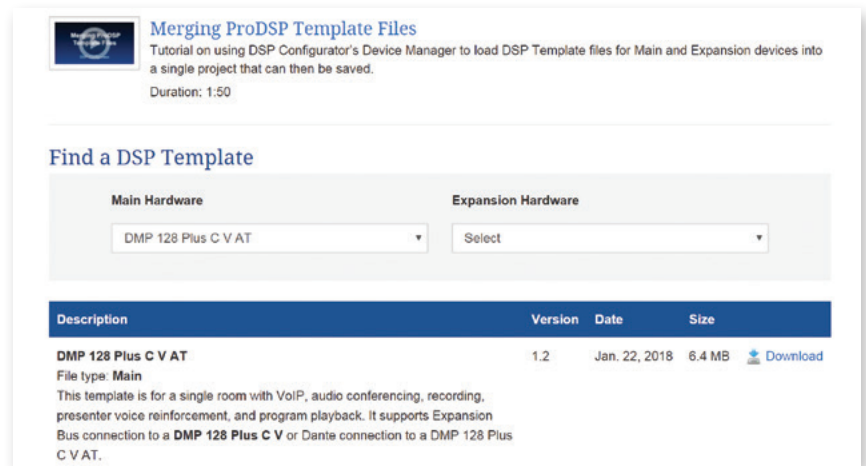

GROUP MASTERS

The DMP 128 Plus provides the capability to consolidate gain or mute control throughout the system. Gain or mute controls can be selected and added to a group master, which can then be controlled by a single master fader or mute control. Up to 64 group masters can be created, each one with up to 128 members.

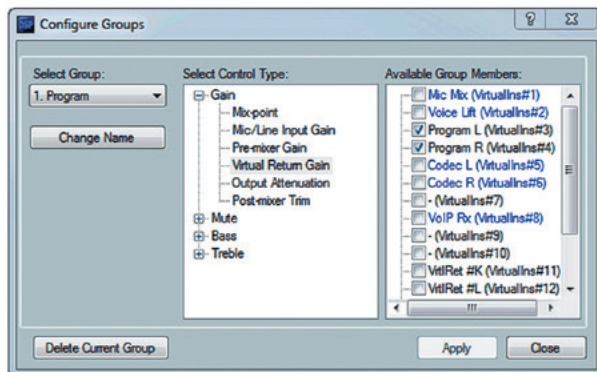

The group master volume range can be limited using soft limits to maintain optimal minimum and maximum levels when using external volume control. This prevents operators from over or under-adjusting levels when using digital I/O, RS-232 or Telnet control. The DSP Configurator Software provides quick drag-and-drop adjustment of soft limits from the Group Controls screen.

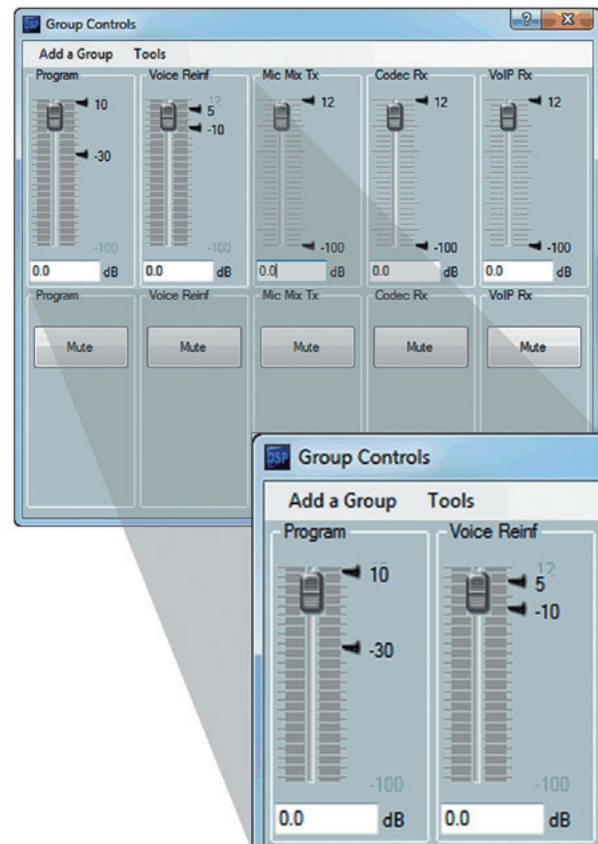

DSP Configurator

1 BUILDING BLOCKS

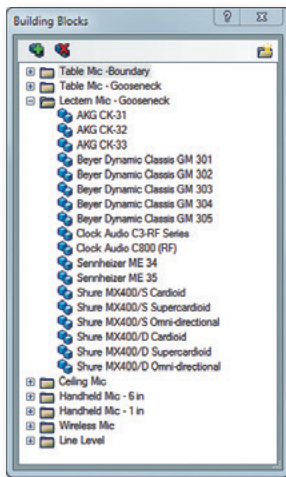

Extron Building Blocks are quick configuration tools for setting up microphones and other sources, speakers, and microphone and program mixes within the processor. Building Blocks provide predetermined gain levels, filters, equalization, and a small amount of protection against signal overload at the output digital-to-analog converters. They can be used to quickly get a sound system up and running, or as a starting point for further system setup and fine-tuning. For additional flexibility, system designers can customize existing Building Blocks or create their own.

ANG GAIN INPUT GAIN

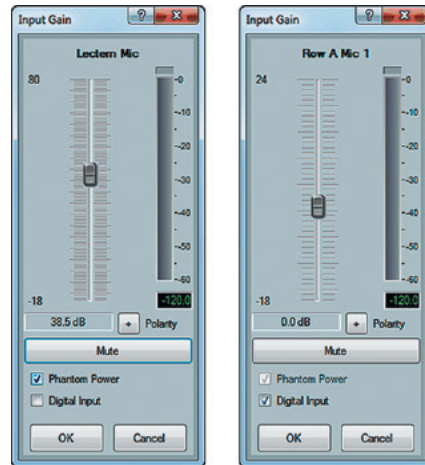

The input gain block for inputs 1-8 offers up to 80 dB of mic gain along with polarity and phantom power controls. In the DMP 128 Plus AT models, these inputs also include a FlexInput capability to accept Dante channels from remote wireless microphones, wallplates, and other sources anywhere on the Dante network, in place of local mic/line inputs 1 - 8. The full range of DSP processing capabilities, including AEC, are available for incoming Dante channels.

PEQ FILTERING



The Filter block offers five customizable filters for each input, five for each virtual bus, and ten for each of the outputs. Each of these filters can be selected as parametric EQ, low pass, high pass, bass and treble shelving or loudness. Standard parameters include frequency, roll-off slope, boost/cut, and Q, depending on the specific filter.

FBS FEEDBACK SUPPRESSION



The FBS - Feedback Suppression Block is used to counteract ringing due to nodes through the microphone and speakers. The feedback suppression processor for the DMP 128 Plus engages up to twenty notch filters with adjustable Q. Fifteen of the filters are dynamic, and the processor automatically detects and then reduces the ringing. Five additional fixed filters can be adjusted manually or transferred from the dynamic filters.

CMP

DYNAMICS & DELAY

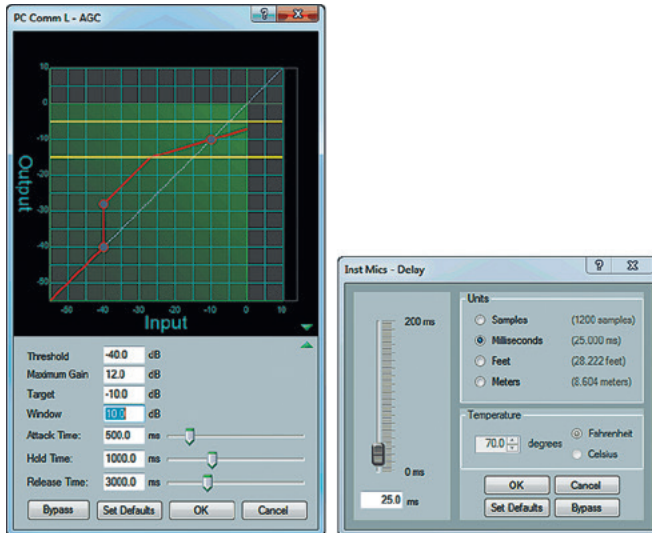

The DSP Configurator Software enables fine-tuning and adjustment of the dynamics of all incoming and outgoing signals. These blocks can be selected and customized to provide automatic gain control, compression, limiting, or noise gating.

A Delay processing block is available for each input, virtual return and output. Each delay is adjustable up to 200 ms, and can be selected in units of samples, time, feet, or meters.

DUCK

DUCKING & ADAPTIVE GAIN

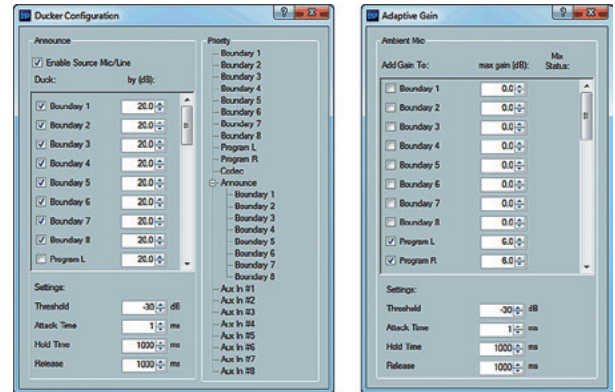

A comprehensive ducking block is available for each input channel. This allows a given input to 'duck' or attenuate one or more other channels in a hierarchical fashion. This is especially useful for paging applications where background music must be turned down automatically to allow everyone to hear the announcement.

An Adaptive Gain block is also available for each input channel. This allows a given input to 'listen' to the ambient noise in an environment and depending upon the level parameters, will boost the level of one or more channels to compensate for excessive noise in the environment.

AEC

ACOUSTIC ECHO CANCELLATION

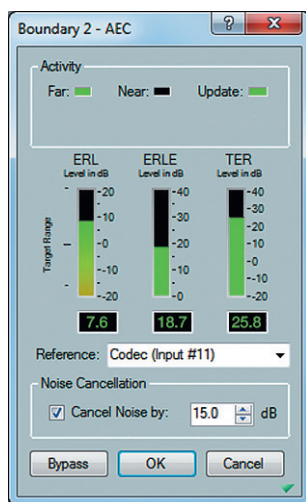

The DSP Configurator Software simplifies AEC and noise cancellation setup with a user-friendly interface that provides real-time metering for ERL - echo return loss, ERLE - echo return loss enhancement, and TER - total echo reduction levels. Guided alerts appear whenever ERL is outside of the optimal range for echo cancellation. Optional settings include fine adjustments for NLP - non-linear processing to maximize AEC performance in acoustic environments with significant sonic reflections or reverberation.

AM1

AUTOMIXING

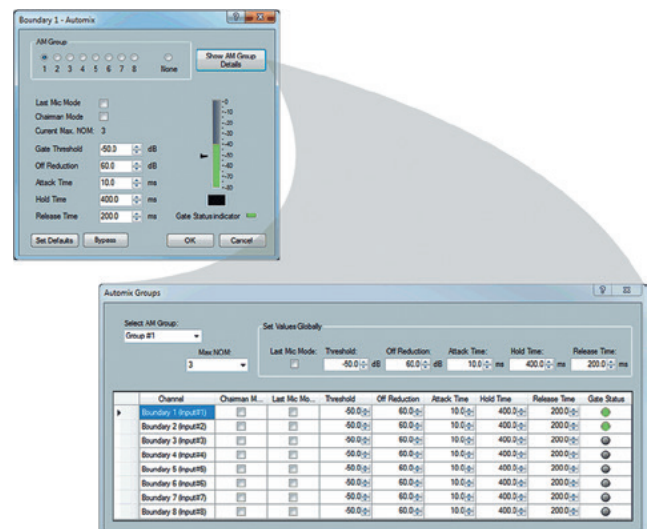

The DMP 128 Plus offers an automixer with gated and gain sharing modes, that can manage up to eight groups of microphone signals. There are several advanced features for optimizing microphone management. Multiple trigger protection activates only the microphone with the highest signal level, while the rest are gated off.

Dante Audio Networking

TECHNOLOGY OVERVIEW

Dante technology from Audinate provides digital audio distribution over standard local area networks. Dante allows high resolution audio channels to be transported uncompressed across a switched Ethernet data network using standard TCP/IP protocols, while meeting the stringent quality requirements of professional audio. Dante was built on the IEEE 1588 Time Precision Protocol standard to derive a precise clocking mechanism for synchronization. As a result of this, latency of one millisecond is maintained across 10 network switch hops using Dante in a Gigabit Ethernet network. Digital audio signals are converted to packets at the edge of the network, then processed and transported to other Dante enabled devices.



Dante™ **Audinate**

A network with Dante enabled devices can be shared with ordinary data traffic such as e-mail. Audio channels can be transported as unicast or multicast to make the most efficient use of available bandwidth.

With Dante, DMP 128 Plus AT processors, AXP Series audio expansion processors and AXI series audio expansion interfaces can share multiple channels of high resolution digital audio with each other over a local area network. They can be directly linked to other processors using their built-in four-port Gigabit Ethernet switches or by connecting into a network infrastructure.

BENEFITS

An IP network of multiple DMP 128 Plus AT and AXP Series processors provides greatly expanded I/O capacity while simplifying cable requirements for transporting dozens or hundreds of audio channels. An input or audio mix at one unit can be directed to any of the other devices on the network, for further DSP processing, mixing, and output to an audio destination such as a speaker zone. A DMP 128 Plus AT or AXP Series processor can also be used to share audio channels with third-party Dante equipped products such as multi-channel audio recorders, amplifiers, or mixing consoles without the need to use any of its local audio input or output ports.

- **Channel flexibility**
Flexible routing matrix of audio channels over standard Gigabit Ethernet networks
- **High quality digital audio**
Compression free, high resolution 24-bit digital audio transport
- **Extremely low latency**
 - Deterministic latency – in the sub-millisecond range with a guaranteed upper limit
 - Applicable for live sound
- **Easy, low cost cable management**
Connectivity using standard CATx cable
- **Flexible IT integration**
 - Uses standard Ethernet switches from Cisco, HP, Juniper Networks, Brocade, Avaya, etc. – simplifies new audio integration projects
 - IT managers have the flexibility to use preferred network switch vendor and network management tools
- **Reduces cost of audio upgrades**
DMP 128 Plus AT processors can be added to an existing IT infrastructure

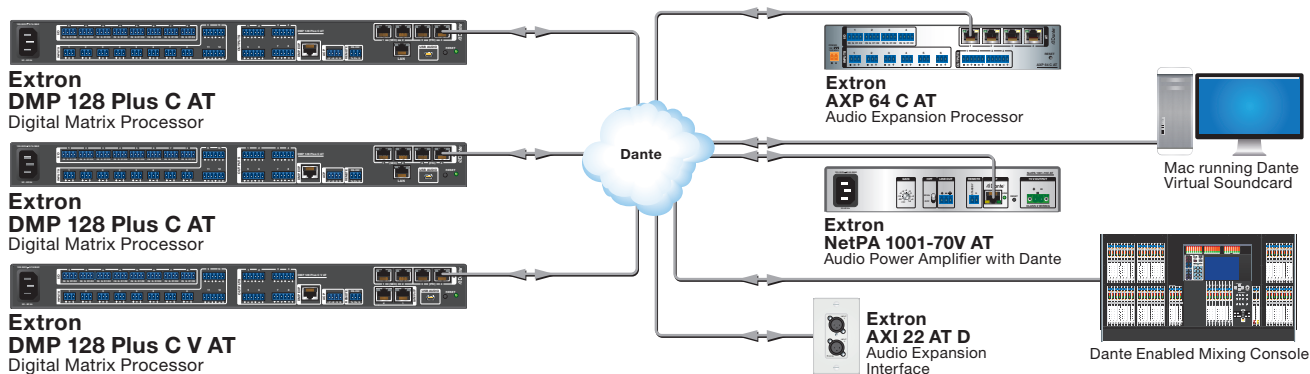

IP-based audio networking with the DMP 128 AT Plus provides inherent scalability, allowing audio systems to be expanded simply by bringing additional processors and third-party Dante enabled devices into the network.

I/O EXPANSION USING AXP SERIES EXPANSION PROCESSORS AND DANTE

AXP Series audio expansion processors are unique in the industry in offering the flexibility of Dante networking to place inputs and outputs in remote locations with full DSP processing, including AEC, to simplify audio cabling infrastructure and reduce cable costs for integrators. A single Ethernet cable from an AXP 50 C AT or AXP 64 C AT audio expansion processor, or several linked units, to a DMP 128 Plus AT processor in a central equipment rack greatly reduces the effort and expense of pulling one cable for each endpoint.

A sound system designer can incorporate several AXP Series processors to create a large mixing matrix with up to 48 remote inputs and 24 outputs per DMP 128 Plus AT, all with 24-bit/48 kHz audio quality. In addition to using the Dante network, multiple DMP 128 Plus AT and AXP Series units can be linked over their integrated four-port Gigabit switches. This greatly simplifies scalability as well as the cabling infrastructure.

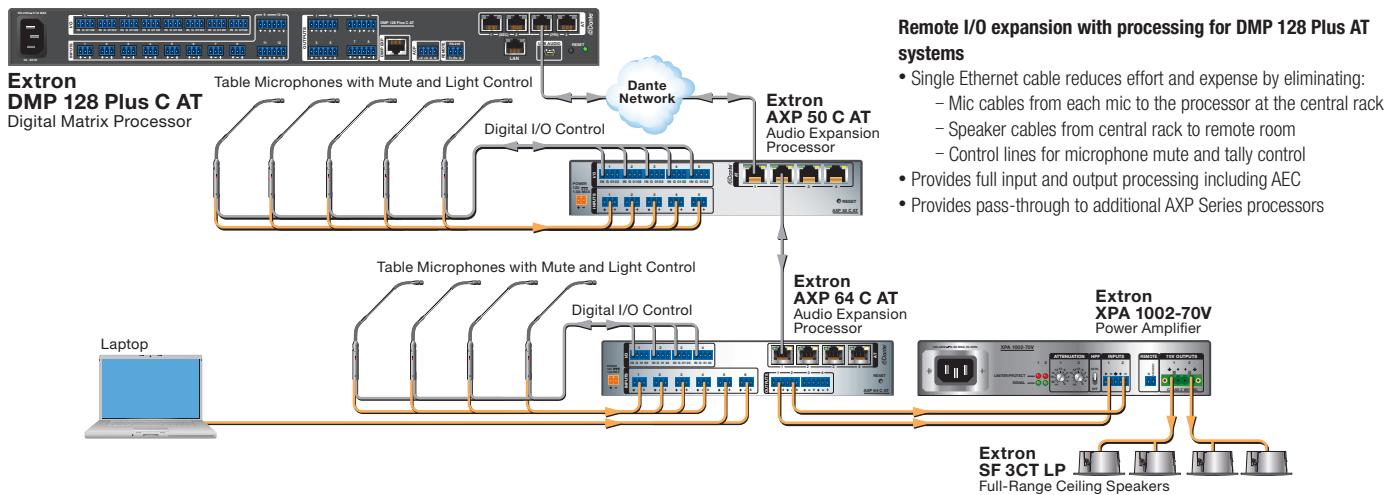

SETUP AND THE DANTE CONTROLLER SOFTWARE

Setting up a network of DMP 128 Plus AT processors is simple and automatic. Once connected, a DMP 128 Plus AT is self-configured with an IP address, and discovered by other processors and Dante enabled devices on the network. A user can route audio channels between devices using the Dante Controller software, which scans the network and provides an intuitive layout of all devices and their input and output channels, including the DMP 128 Plus AT processors and their 48 available inputs and 24 outputs. Making audio routing assignments between devices is very simple with just a few clicks of a mouse.

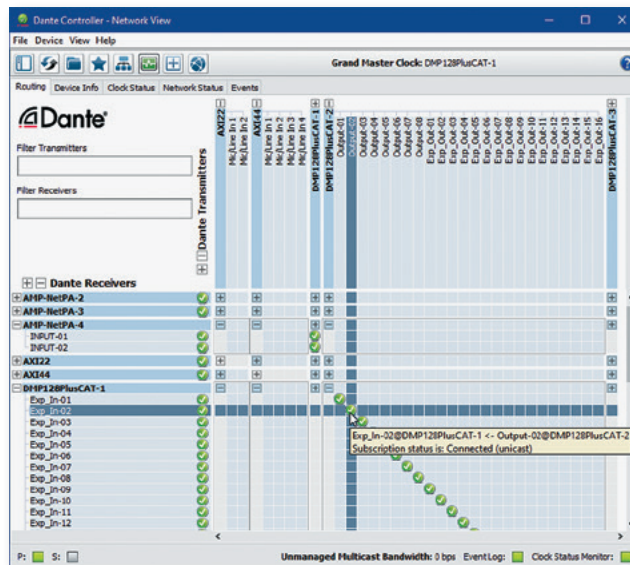

Audio Control Panels

ACP Series audio control panels are ideal for use in applications that require a simple and cost-effective means to control basic audio functions. No control system is necessary. Mounted in a lectern, the an ACP Series control panel can provide easy access to mic volume, program volume, and source selection. Mounted on a wall, the ACP Series provides an easy means of controlling individual and combined speaker zones in divisible meeting spaces. Since they have the same physical appearance as Extron's broad range of MediaLink controllers, ACP Series control panels can be used alongside them throughout a facility while preserving a consistent look and user experience. Buttons can be easily customized using Extron Button Label Generator software.



ACP 100

Audio Control Panel with Volume and 6 Control Buttons – US 2-Gang

- Six dual-color, customizable back-lit buttons and rotary volume control
- Volume control knob with LEDs for visual feedback
- Mounts in a two-gang junction box

ACP 106 D

Audio Control Panel with 6 Buttons – Decorator-Style

- Six customizable backlit buttons with white LEDs
- Volume adjustment buttons with LED level indication
- Mounts in a single gang junction box, and includes white decorator-style wallplate

Model	Version Description	Part Number	Model	Version Description	Part Number
ACP 100	2-Gang US, White, 6 Button w/Rotary Volume Control	60-1643-03	ACP 106 D	1-Gang Decorator-Style, White, 6 Button	60-1645-03



ACP 106 EU

Audio Control Panel with 6 Buttons – EU

- Six customizable backlit buttons with white LEDs
- Volume adjustment buttons with LED level indication
- Compatible with Flex55 modules and enclosures, as well as EU junction boxes

ACP 106 MK

Audio Control Panel with 6 Buttons – MK

- Six customizable backlit buttons with white LEDs
- Volume adjustment buttons with LED level indication
- Includes white MK wall frame and mounting bracket

Model	Version Description	Part Number	Model	Version Description	Part Number
ACP 106 EU	1-Gang EU and Flex55, White, 6 Button	60-1650-03	ACP 106 MK	1-Gang MK, White, 6 Button	60-1651-03

CONFIGURING AUDIO CONTROL PANELS

ACP Panels are configured within DSP Configurator under the Tools pull-down menu. This allows the selection of an ACP Panel Type and the ID# that matches the physical address of the ACP Panel. Three control types are available for each button,

Action-Fixed – The button will have a single function, such as volume, mute, preset recall or macro recall.

Action-Follow Selector – The volume or mute function will change according to which “Selector Vol/Mute” button is activated.

Selector Vol/Mute – A set of buttons that change which group volume and mute controls are active.

Up to four ACP panels can be connected to each DMP 128 Plus.

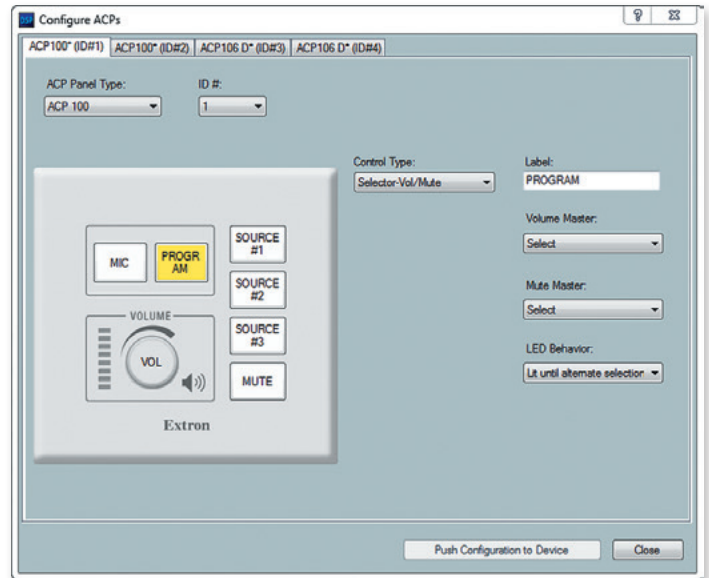

MEETING ROOMS

In this application, we have two meeting rooms that run on a single DMP 128 Plus. The FlexInput option allows two AXI 22 AT D panels in room A to feed microphones to inputs 1-4. Similarly, two AXI 22 AT D panels in room B feed microphones to inputs 5-8. Analog outputs feed an Extron XPA 2002-70V, channel one driving speakers for room A and channel two driving speakers for room B.

These two meeting rooms operate independently, with each ACP series panel adjusting audio levels for its respective room. When combined into one large space, both of the ACP panels function in parallel, affecting levels and sources for both rooms.

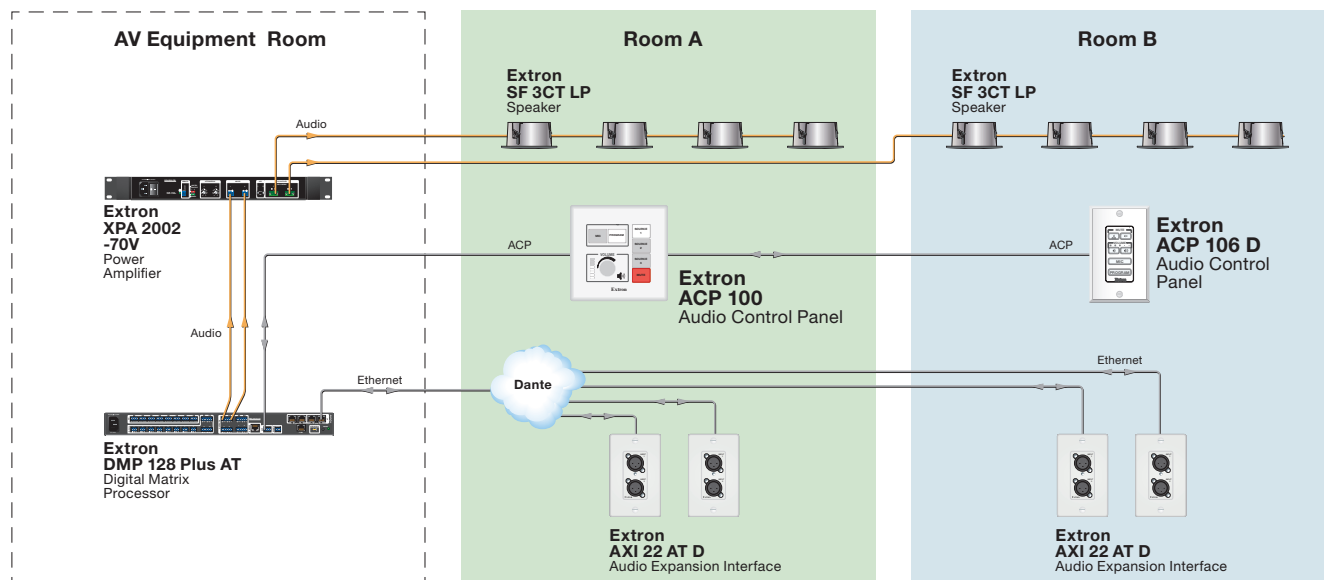

Applications

CONFERENCE ROOM

The DMP 128 Plus provides a diversity of audio functions to support various applications. In the conference room application below, eight boundary microphones are placed around a conference table and fed to inputs 1-8 of the DMP 128 Plus C V. The Room PC and conference table laptop feed the DTP Crosspoint 82 4K IPCP MA, which in turn feeds video to the display and audio to the DMP 128 Plus C V via the DMP Expansion bus.

The USB port on the DMP 128 Plus C V provides a convenient method for interfacing with the soft codec on the Room PC. Conference calls are handled through the VoIP port on the DMP 128 Plus C V.

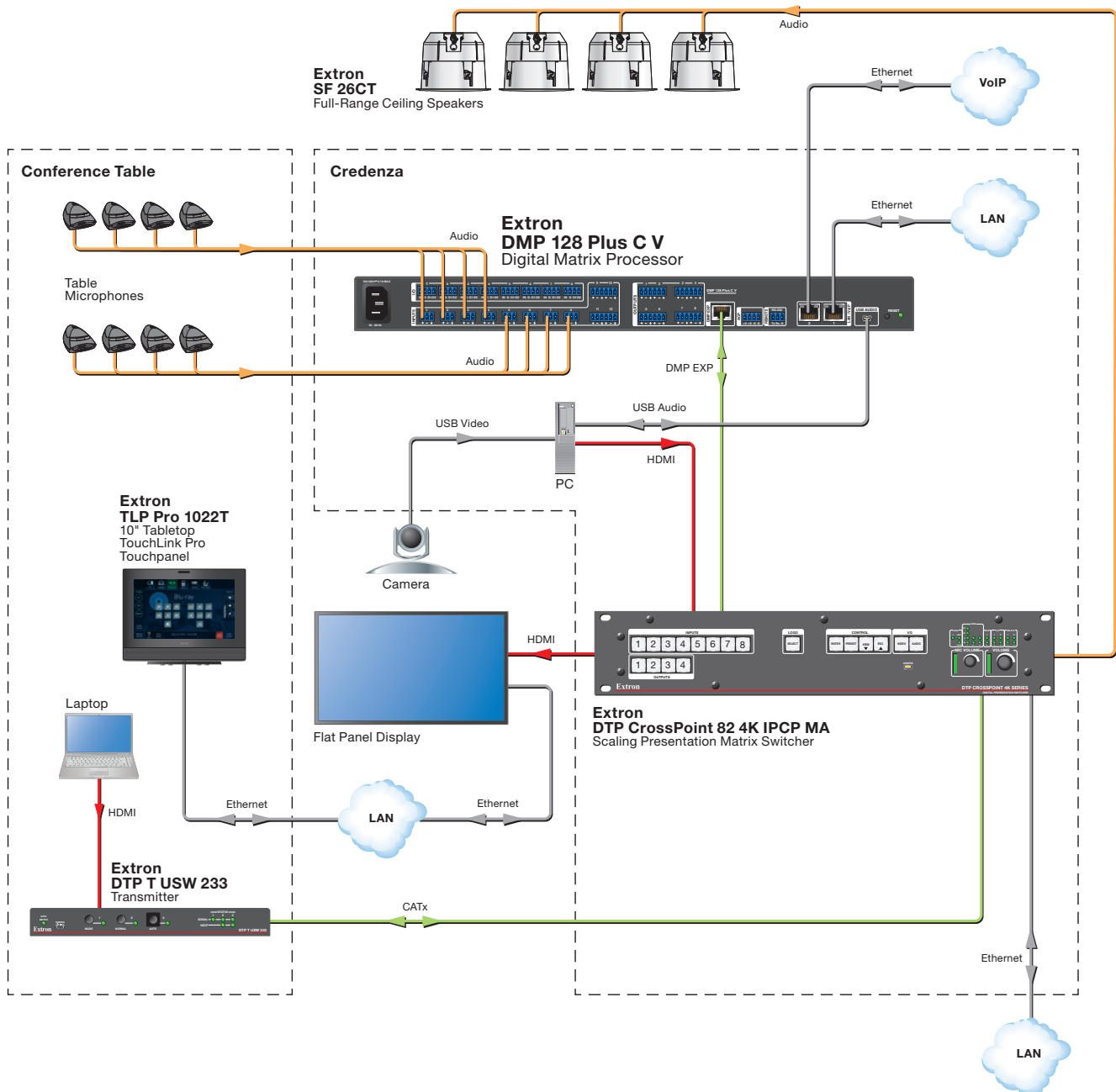

TRAINING ROOM

In this training room application, two DMP 128 Plus C AT units and one DTP Crosspoint 84 4K IPCP SA handle the lectern microphones, the wireless microphones and the 16 student microphones. Program audio from the various sources is routed from the DTP Crosspoint 84 4K IPCP SA to the DMP 128 Plus C AT units through the Extron DMP Expansion bus. Program Playback is routed to the two Extron SM 28 speakers, powered from the stereo amplifier included in the DTP Crosspoint 84 4K IPCP SA. Voice Reinforcement is distributed across two speaker zones via Dante signals to the four Extron NetPA 1001-70V amplifiers.

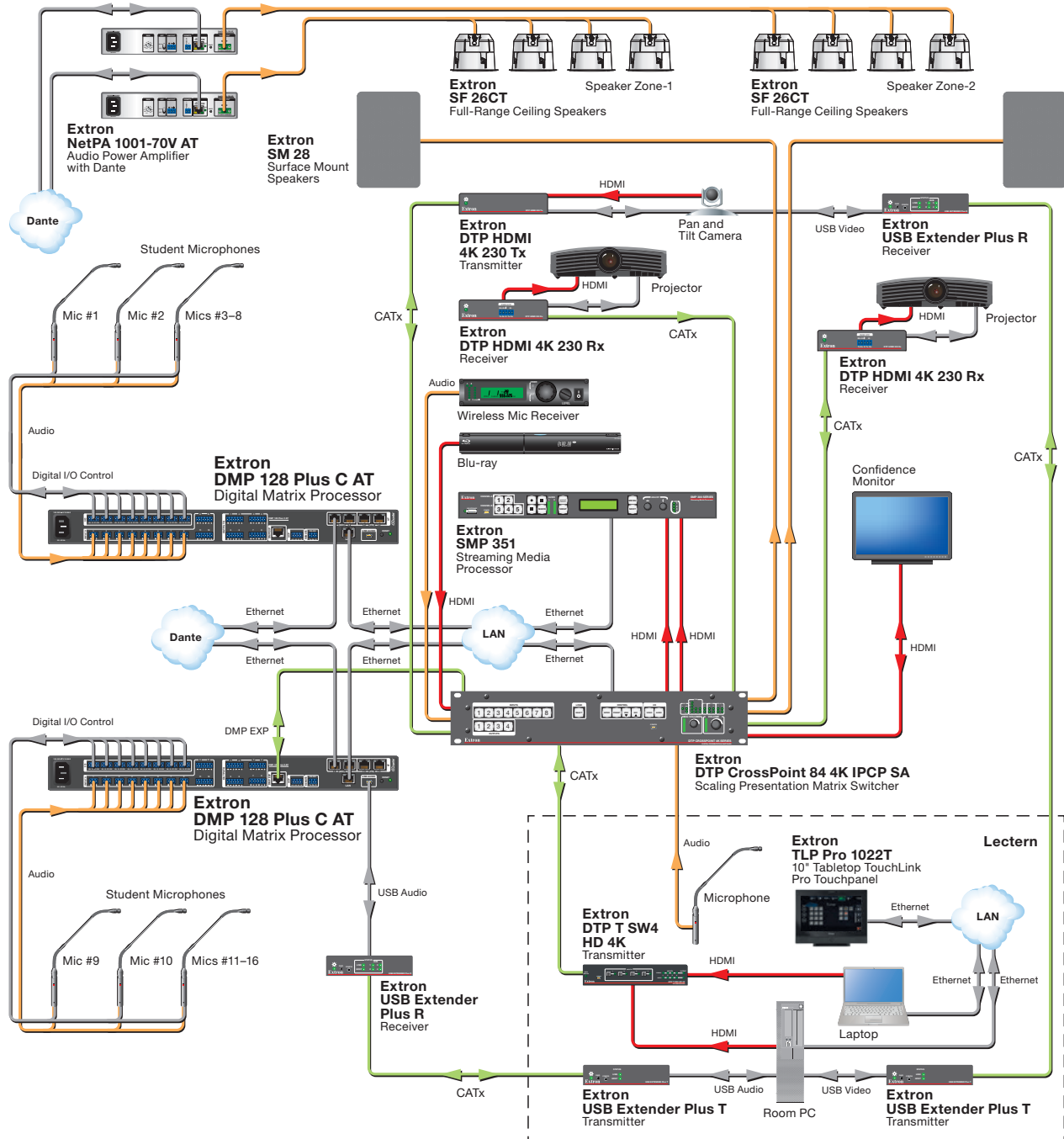

Applications

COURTROOM

The DMP 128 Plus is ideal for meeting the different functional requirements for audio in a courtroom. The automixer is a particularly beneficial feature in courtroom proceedings, automatically managing microphone levels to maintain proper system gain before feedback and ensuring everything is clearly heard, whether one person or multiple people are speaking. The automixer features a “chairman mode” which can gate off all mics whenever the judge is addressing the courtroom. The DMP 128 Plus includes eight outputs for sound reinforcement as well as an audio recorder and ALS - assistive listening system. Presets can be created with specific mics shut off, outputs to the audio recorder muted, or other functions or settings to support situations such as sidebar discussions between counsel and the judge.

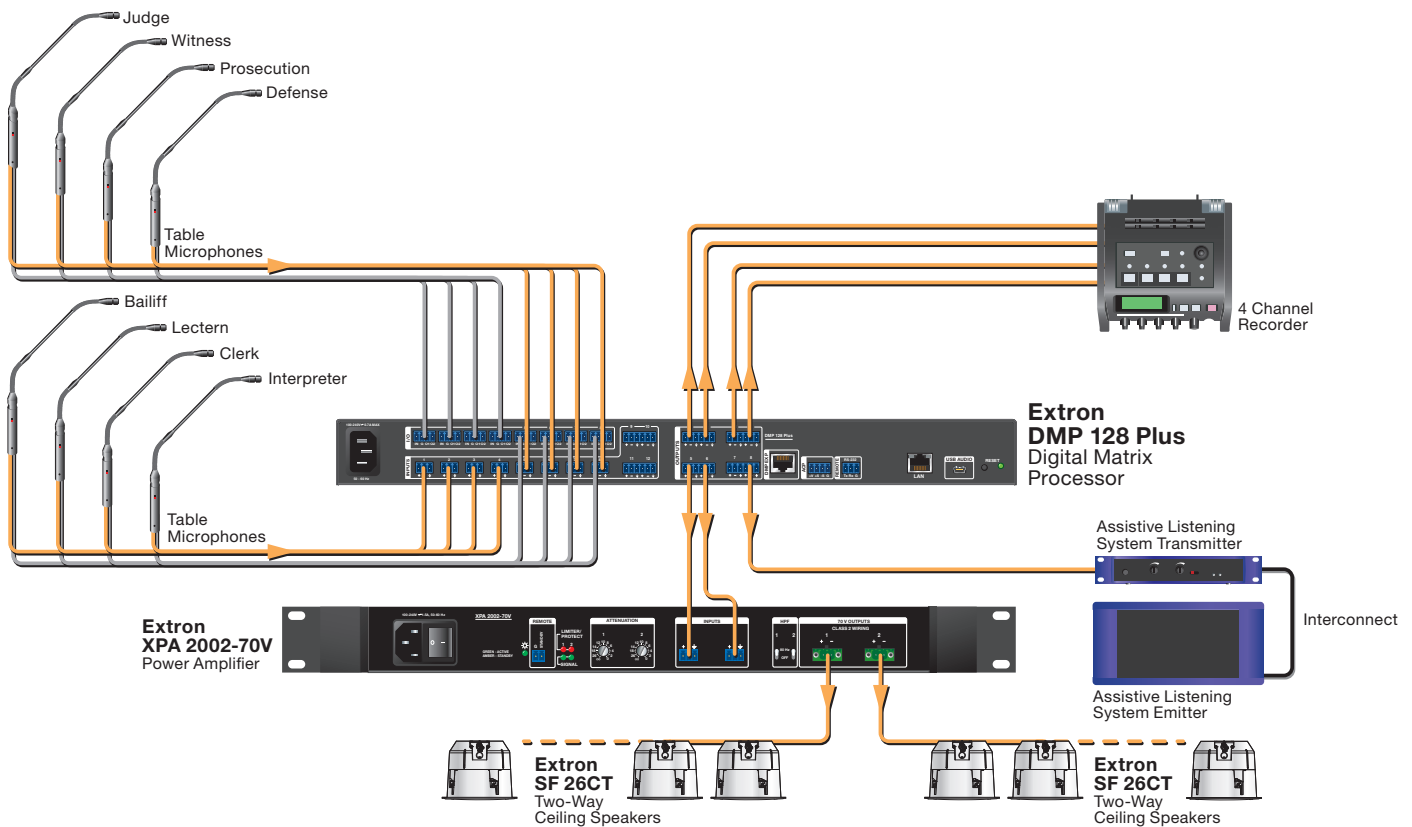

CLASSROOM

In this classroom application, a single DMP 128 Plus C unit and one DTP CrossPoint 84 4K IPCP MA 70 handle the lectern microphone, the wireless microphone and the 8 student microphones. Program audio from the various sources are routed from the DTP CrossPoint 84 4K IPCP MA 70 to the DMP 128 Plus C unit through the Extron DMP Expansion bus. Ceiling speakers are powered from the amplifier included in the DTP CrossPoint 84 4K IPCP MA 70. Ceiling speakers are powered from the amplifier included in the DTP CrossPoint 84 4K IPCP MA 70.

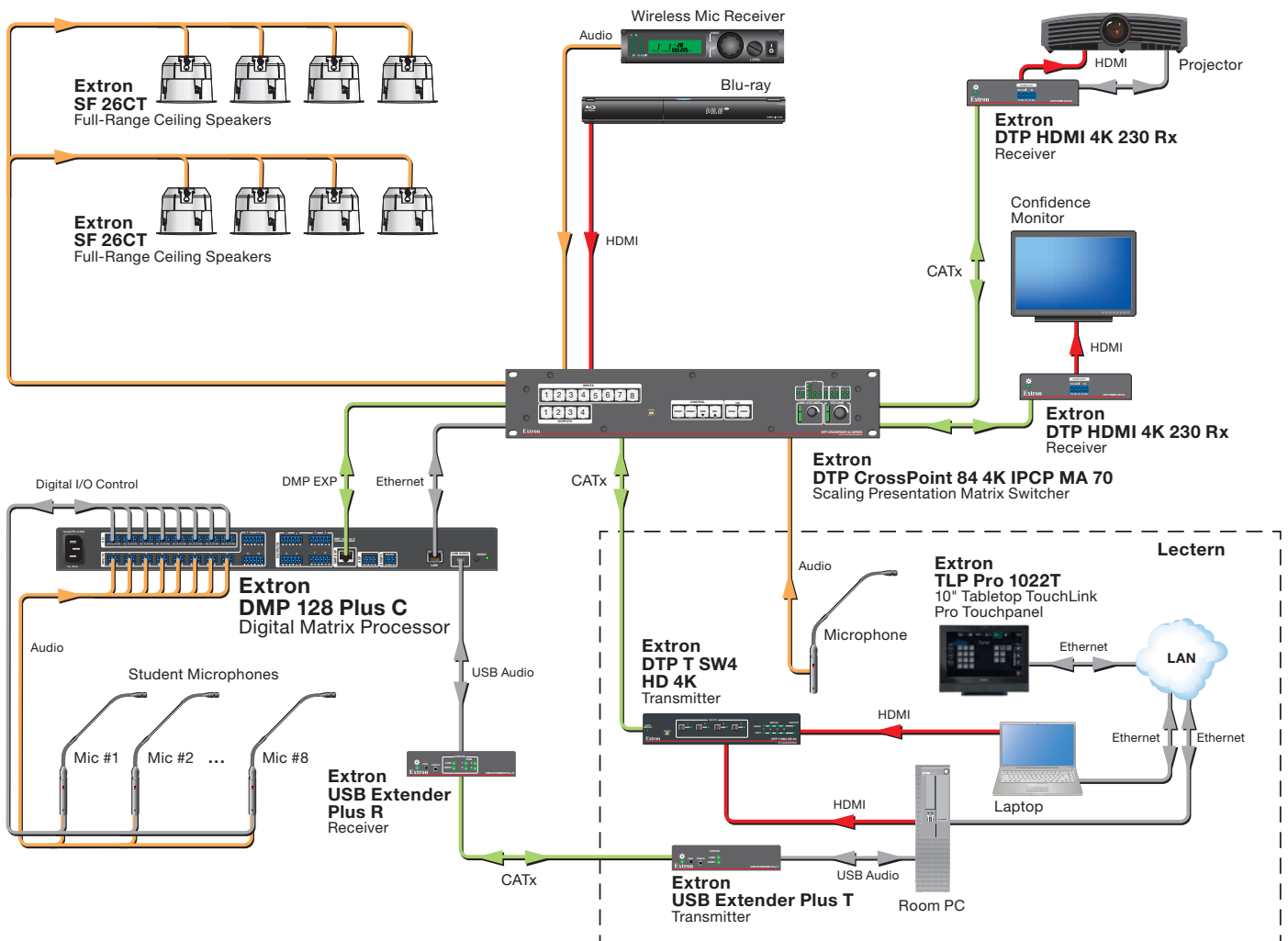

Specifications

AUDIO SYSTEM	
Gain	Unbalanced output: -6 dB; balanced output: 0 dB
Frequency response	20 Hz to 20 kHz, ± 0.2 dB
THD + Noise	<0.01%, 20 Hz to 20 kHz, at maximum level
S/N	
Analog In to Analog Out	>107 dB, 20 Hz to 20 kHz, at maximum balanced output, unweighted
Analog In to Digital Out	110 dB, 20 Hz to 20kHz, at maximum balanced output, unweighted
Digital In to Analog Out	115 dB, 20 Hz to 20kHz, at maximum balanced output, unweighted
Crosstalk	<-90 dB @ 20 Hz to 20 kHz, fully loaded
AUDIO INPUT	
Number/signal type	12 mono, mic/line, balanced/unbalanced, 8 with phantom power, 4 without phantom power
Connectors	(8) 3.5 mm captive screw connectors, 3 pole mono, balanced/unbalanced (with phantom power) (2) 3.5 mm captive screw connectors, 6 pole, mono, balanced/unbalanced (without phantom power)
Impedance	>10k ohms unbalanced/balanced
Nominal level	-60 dBV, +4 dBu, -10 dBV adjustable via input gain
Maximum level	+21 dBu at rated THD+N when mic gain is set to 0 dB
DC phantom power	+48 VDC, $\pm 10\%$ (inputs 1-8) can be switched on or off per input
AUDIO OUTPUT	
Number/signal type	8 mono (or 4 stereo), line, balanced/unbalanced
Connectors	(4) 3.5 mm captive screw connectors, 6 pole
Impedance	50 ohms unbalanced, 100 ohms balanced
Maximum level (Hi-Z)	>+21 dBu balanced, >+15 dBu unbalanced
AUDIO PROCESSING	
A/D, D/A conversion	24 bit, 48 kHz sampling
AEC tail length	>200 msec
AEC convergence	up to 60 dB/sec
Noise cancellation	up to 20dB, software selectable
EXP PORT	
Connectors	1 RJ-45 connector
Inputs	16 channels Rx
Outputs	16 channels Tx
Audio format	24 bit, 48 kHz sampling, uncompressed
EXP cable	Shielded CAT6 up to 10 meters (1 foot cable included)
USB AUDIO PORT	
Connectivity	1 rear panel female mini USB connector
Protocol	USB 2.0, high speed
AT PORTS (DMP 128 PLUS AT MODELS ONLY) – AUDIO TRANSPORT	
Transmission type	Dante/AES-67, software selectable
Connectors	4 RJ-45 connectors, 4-port 1 Gbps switch to Dante interface
Inputs	48 channels Rx
Outputs	24 channels Tx
VOIP PORT (DMP 128 PLUS V MODELS ONLY)	
Host port	1 RJ-45 female connector
Data rate	10/100/1000 Base-T

Signaling protocol	Session Initiation Protocol (SIP), RFC 3261 and related RFCs	
Discovery protocol	LLDP-MED (optional)	
Lines	Up to 8 concurrent, independent extensions	
Codec support	Various ITU, including wideband	
VoIP default settings	Link speed and duplex level = autodetected IP address = 192.168.1.254 Subnet mask = 255.255.255.0 Default gateway = 0.0.0.0 DHCP = off	
CONTROL/REMOTE		
Serial host control port	1 bidirectional RS-232, 3.5 mm captive screw connector, 3 pole	
USB control ports	1 front panel female mini USB B	
ACP control ports	1 = +12V, 2 = +S, 3 = -S, 4 = G	
Digital I/O	(8) 3.5 mm captive screw connectors, 4 pole 1 = In, 2 = G, 3 = Out 1, 4 = Out 2 Input voltage range = 0V to +12V Output voltage = 0V (low), 5V (high) Software programmable	
Ethernet host port	1 RJ-45 female connector	
Ethernet protocol	ARP, ICMP, IP, TCP, DHCP, HTTPS, Telnet, SSH	
Web server	Up to 200 simultaneous sessions	
Program control	Extron control/configuration program for Windows® Extron Simple Instruction Set (SIS™) Microsoft® Internet Explorer®, Telnet	
GENERAL		
Power	Internal Input: 100-240 VAC, 50-60 Hz Consumption: 29.4 watts	
Mounting	Rack mount Furniture mount	
Enclosure dimensions	1.7" H x 17.4" W x 9.5" D (1U high, full rack wide) (4.3 cm H x 44.2 cm W x 24.1 cm D) (Depth excludes connectors.)	
Product weight	4.5 lbs	
Regulatory compliance	Safety CE, c-UL, UL EMV/EMC CE, C-Tick, FCC Class A, ICES, VCCI Environmental Complies with the appropriate requirements of RoHS, WEEE	
Warranty	3 years parts and labor	
NOTE: All nominal levels are at $\pm 10\%$.		
Model	Version Description	Part number
DMP 128 Plus	12x8 ProDSP Processor	60-1511-01
DMP 128 Plus AT	12x8 ProDSP Processor w/Dante	60-1511-10
DMP 128 Plus C	12x8 ProDSP Processor w/AEC	60-1512-01
DMP 128 Plus C AT	12x8 ProDSP Processor w/AEC, and Dante	60-1512-10
DMP 128 Plus C V	12x8 ProDSP Processor w/AEC, and VoIP	60-1513-01
DMP 128 Plus C V AT	12x8 ProDSP Processor w/AEC, VoIP and Dante	60-1513-10

For complete specifications, please go to www.extron.com
Specifications are subject to change without notice.

WORLDWIDE SALES OFFICES

Anaheim • Raleigh • Silicon Valley • Dallas • New York • Washington, DC • Toronto • Mexico City • Paris • London
Frankfurt • Madrid • Stockholm • Amersfoort • Moscow • Dubai • Johannesburg • Tel Aviv • Sydney • Melbourne
Bangalore • Mumbai • New Delhi • Singapore • Seoul • Shanghai • Beijing • Hong Kong • Tokyo

www.extron.com